

June 2011

DESCRIPTION

The HI-8591 is an ARINC 429 bus interface receiver designed to operate from a single 3.3 V or 5 V supply. The part is designed with high-impedance inputs to minimize bus loading, and has an exceptional input common-mode performance in excess of +/- 30V, making it immune to ground offsets around the aircraft. The RINA and RINB inputs of the standard HI-8591 may be connected directly to the ARINC 429 bus. To enable external lightning protection circuitry to be added, the HI-8591-40 variant is available. The HI-8591-40 requires only the addition of external 40 KΩ, ¼ watt resistors in series with RINA and RINB to allow the part to meet the lightning protection requirements of DO-160D level 3.

The typical 10 volt differential ARINC 429 signal is translated and input to a window comparator and latch. The comparator levels are set just below the standard 6.5 volt minimum ARINC data threshold and just above the standard 2.5 volt maximum ARINC null threshold.

The TESTA and TESTB inputs bypass the analog inputs for testing purposes. Also if TESTA and TESTB are both taken high, the digital outputs are forced to zero.

See Holt Application Note AN-300 for more information on lightning protection.

FEATURES

- ARINC 429 line receiver interface in a small outline package
- 3.3V single rail supply voltage
- +/-30 V common-mode performance
- >140 KOhm input impedance
- Lightning protection simplified with the ability to add 40 KOhm external series resistors
- Receiver input hysteresis at least 2 volt
- Test inputs bypass analog inputs and force digital outputs to a one, zero or null state

PIN CONFIGURATIONS

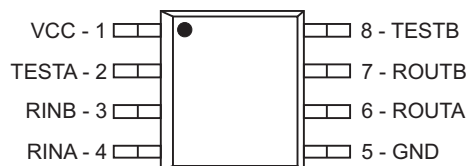

**HI-8591PSI, HI-8591PST & HI-8591PSM
HI-8591PSI-40, HI-8591PST-40 & HI-8591PSM-40**
8 - PIN PLASTIC NARROW BODY SOIC

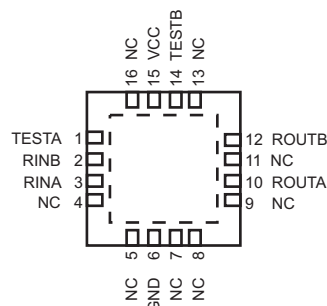

HI-8591PCI, HI-8591PCT, HI-8591PCI-40 & HI-8591PCT-40
16- pin 4mm x 4mm Chip-scale package

SUPPLY VOLTAGES

VCC = 3.3V ± 10%, 5.0V ± 10%

FUNCTION TABLE

RINA	RINB	TESTA	TESTB	ROUTA	ROUTB
-1.25V to 1.25V	-1.25V to 1.25V	0	0	0	0
-3.25V to -6.5V	3.25V to 6.5V	0	0	0	1
3.25V to 6.5V	-3.25V to -6.5V	0	0	1	0
X	X	0	1	0	1
X	X	1	0	1	0
X	X	1	1	0	0

PIN DESCRIPTION TABLE

SYMBOL	FUNCTION	DESCRIPTION
VCC	SUPPLY	3.3V or 5V SUPPLY
TESTA	LOGIC INPUT	CMOS
RINB	ARINC INPUT	RECEIVER B INPUT
RINA	ARINC INPUT	RECEIVER A INPUT
GND	POWER	GROUND
ROUTA	LOGIC OUTPUT	RECEIVER CMOS OUTPUT A
ROUTB	LOGIC OUTPUT	RECEIVER CMOS OUTPUT B
TESTB	LOGIC INPUT	CMOS

FUNCTIONAL DESCRIPTION

RECEIVER

Figure 1 shows the general architecture of the ARINC 429 receiver. The receiver operates off the VCC supply only. The inputs RINA and RINB each require 140KΩ of resistance between the ARINC bus and comparator. This resistance is completely on-chip for the HI-8591. In contrast, the HI-8591-40 has 100 KΩ on-chip and requires an external 40KΩ, ¼ watt resistor on each of the ARINC 429 input pins. The HI-8591-40 device is typically chosen for applications where lightning protection is a requirement.

After level translation, the inputs are buffered and become inputs to a differential amplifier. The amplitude of the differential signal is compared to levels derived from a divider between V.C. and Ground. The nominal settings corre-

spond to a One/Zero amplitude of 6.0V and a Null amplitude of 3.3V.

The status of the ARINC receiver input is latched. A Null input resets the latches and a One or Zero input sets the latches.

The logic at the output is controlled by the test signal which is generated by the logical OR of the TESTA and TESTB pins. If TESTA and TESTB are both One, the HI-8591 outputs are pulled low. This allows the digital outputs of a transmitter to be connected to the test inputs through control logic for system self-test purposes.

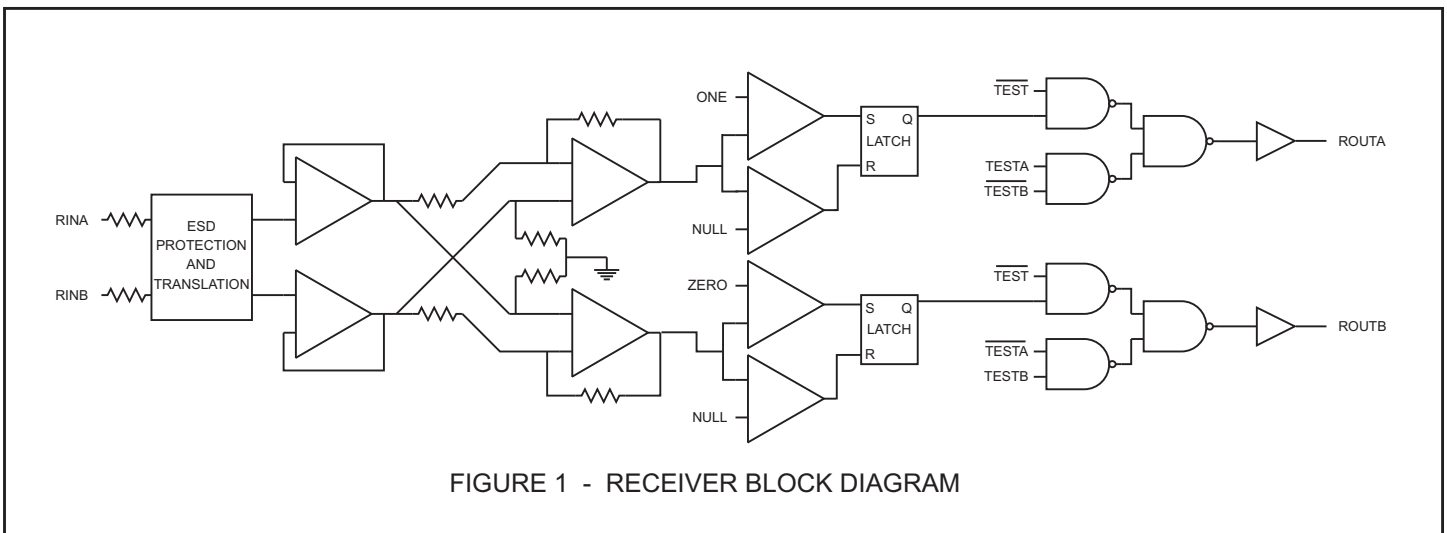

FIGURE 1 - RECEIVER BLOCK DIAGRAM

APPLICATION INFORMATION

Figure 2 shows a possible application of the HI-8591 interfacing an ARINC 429 bus input to a 3.3V ASIC or FPGA. In this example a HI-8586 ARINC 429 line driver is used to take 3.3V logic outputs and generate the necessary 10V differential signal for driving an ARINC 429 bus.

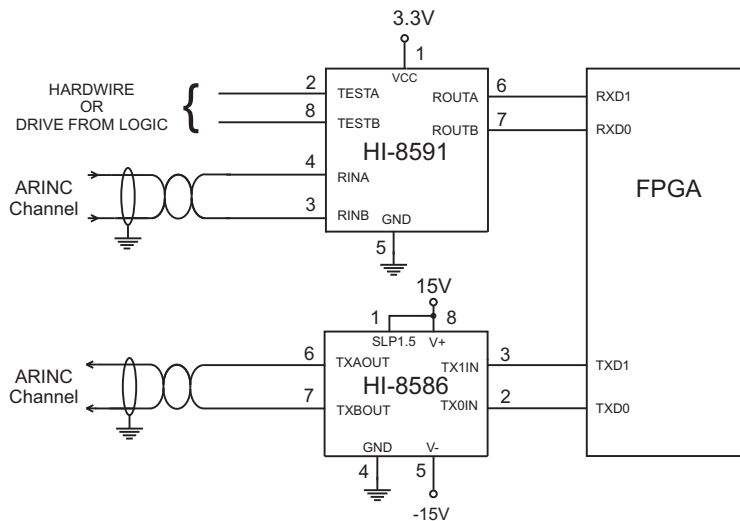

FIGURE 2 - APPLICATION DIAGRAM

ABSOLUTE MAXIMUM RATINGS

Voltages referenced to Ground

Supply voltages VCC.....-0.3V to +7V
ARINC input - pins 3 & 4 Voltage at either pin.....+120V to -120V
DC current per input pin..... ±10mA
Power dissipation at 25°C plastic DIP.....0.7W ceramic DIP.....0.5W
Solder Temperature275°C for 10 sec
Storage Temperature.....-65°C to +150°C

RECOMMENDED OPERATING CONDITIONS

Supply Voltages VCC.....3.3V to 5V ± 10%
Temperature Range Industrial Screening.....-40°C to +85°C Hi-Temp Screening.....-55°C to +125°C Military Screening.....-55°C to +125°C

NOTE: Stresses above absolute maximum ratings or outside recommended operating conditions may cause permanent damage to the device. These are stress ratings only. Operation at the limits is not recommended.

DC ELECTRICAL CHARACTERISTICS

OPERATING TEMPERATURE RANGE, VCC = 3.3V ± 10% or 5.0V ± 10% UNLESS OTHERWISE STATED

PARAMETERS	SYMBOL	TEST CONDITIONS	MIN	TYP	MAX	UNITS
ARINC input voltage one or zero null common mode	V _{DIN} V _{NIN} V _{COM}	Differential volt., pins 3 & 4 " " " with respect to ground	6.5 - -30.0	10 - -	13 2.5 +30.0	volts volts volts
logic input voltage high low	V _{IH} V _{IL}		70% VCC -	- -	- 30% VCC	volts volts
ARINC input resistance R _{INA} to R _{INB} R _{INA} or R _{INB} to GND R _{INA} or R _{INB} to VCC	R _{DIFF} R _{GND} R _{VCC}	Supplies floating " " " "	- - -	140 140 100	- - -	KΩ KΩ KΩ
logic input current source sink	I _{IH} I _{IL}	V _{IN} = 2.0V V _{IN} = 0.8V	- -	- -	20.0 20.0	μA μA
logic output drive voltage one zero	V _{OH1} V _{OH2} V _{OL1} V _{OL2}	VCC = 5V ± 10% I _{OH} = 5mA VCC = 3.3V ± 10% I _{OH} = 1.5mA VCC = 5V ± 10% I _{OH} = 5mA VCC = 3.3V ± 10% I _{OH} = 1.5mA	2.4 2.4 - -	- - - -	- - 0.5 0.4	V V V V
Current drain operating	I _{CC1}	pins 2, 8 = 0V; pins 3, 4 open	-	1.5	5.0	mA

AC ELECTRICAL CHARACTERISTICS

OPERATING TEMPERATURE RANGE, $V_{CC} = 3.3V \pm 10\%$ or $5.0V \pm 10\%$ UNLESS OTHERWISE STATED

PARAMETERS	SYMBOL	TEST CONDITIONS	MIN	TYP	MAX	UNITS
Receiver propagation delay		defined in Figure 3, $C_L = 50pF$				
Output high to low	t_{plhr}	$V_{CC} = 3.3V \pm 10\%$	-	600	1000	ns
		$V_{CC} = 5.0V \pm 10\%$	-	600	900	ns
Output low to high	t_{plhr}	$V_{CC} = 3.3V \pm 10\%$	-	600	1000	ns
		$V_{CC} = 5.0V \pm 10\%$	-	600	900	ns
TEST pin propagation delay		defined in Figure 4, $C_L = 50pF$				
Output high to low	t_{pth}	$V_{CC} = 3.3V \pm 10\%$	-	-	100	ns
		$V_{CC} = 5.0V \pm 10\%$	-	-	60	ns
Output low to high	t_{ptl}	$V_{CC} = 3.3V \pm 10\%$	-	-	100	ns
		$V_{CC} = 5.0V \pm 10\%$	-	-	60	ns
Receiver output transition times		$V_{CC} = 3.3V$ or $5.0V \pm 10\%$				
Output high to low	t_{fr}		-	15	50	ns
Output low to high	t_{rr}		-	15	50	ns
Input capacitance (1)						
ARINC differential	C_{AD}		-	5	10	pF
ARINC single ended to Ground	C_{AS}		-	-	10	pF
Logic	C_{IN}		-	-	10	pF

Notes: 1. Guaranteed but not tested

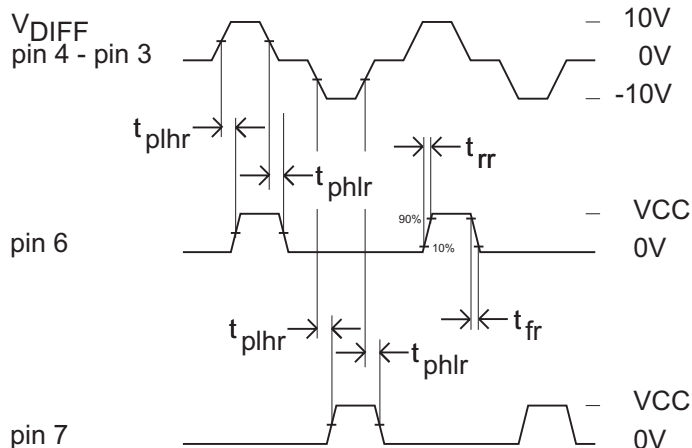

FIGURE 3 - RECEIVER TIMING

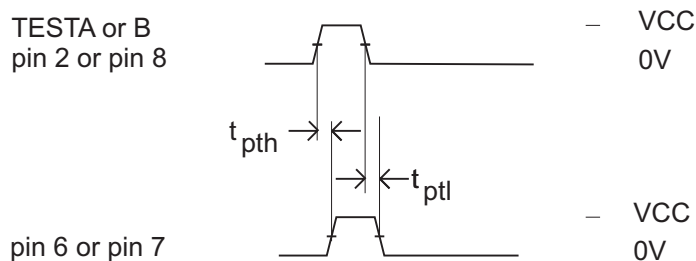

FIGURE 4 - TEST PIN TIMING

HEAT SINK - CHIP-SCALE PACKAGE ONLY

The HI-8591PCI and HI-8591PCT use a 16-pin plastic chip-scale (QFN) package. This package has a metal heat sink pad on its bottom surface. This heat sink should be soldered down to the printed circuit board for optimum thermal dissipation. The heat sink is electrically isolated

from the chip and can be soldered to any ground or power plane. However, since the chip's substrate is at V+, connecting the heat sink to this power plane is recommended to avoid coupling noise into the circuit.

ORDERING INFORMATION

HI - 8591 xx x x - xx

PART NUMBER	INPUT SERIES RESISTANCE	
	BUILT-IN	REQUIRED EXTERNALLY
No dash number	140 Kohm	0
-40	100 Kohm	40 Kohm

PART NUMBER	LEAD FINISH
Blank	Tin / Lead (Sn / Pb) Solder
F	100% Matte Tin (Pb-free, RoHS compliant)

PART NUMBER	TEMPERATURE RANGE	FLOW	BURN IN
I	-40°C TO +85°C	I	NO
T	-55°C TO +125°C	T	NO
M	-55°C TO +125°C	M	YES

PART NUMBER	PACKAGE DESCRIPTION
PC	16 PIN PLASTIC 4 x 4 mm CHIP SCALE (16PCS) not available with "M" flow
PD	8 PIN PLASTIC DIP (8P) not available with "M" flow
PS	8 PIN PLASTIC NARROW BODY SOIC (8HN)
CR	8 PIN Cerdip (8D) not available Pb-free

REVISION HISTORY

P/N	Rev	Date	Description of Change
DS8591	F	06/21/11	Updated pad & heat-sink dimensions on 16-pin plastic chip-scale (QFN) package to reflect current package vendor's dimensions.

8-PIN PLASTIC SMALL OUTLINE (SOIC) - NB
(Narrow Body)

inches (millimeters)
Package Type: 8HN

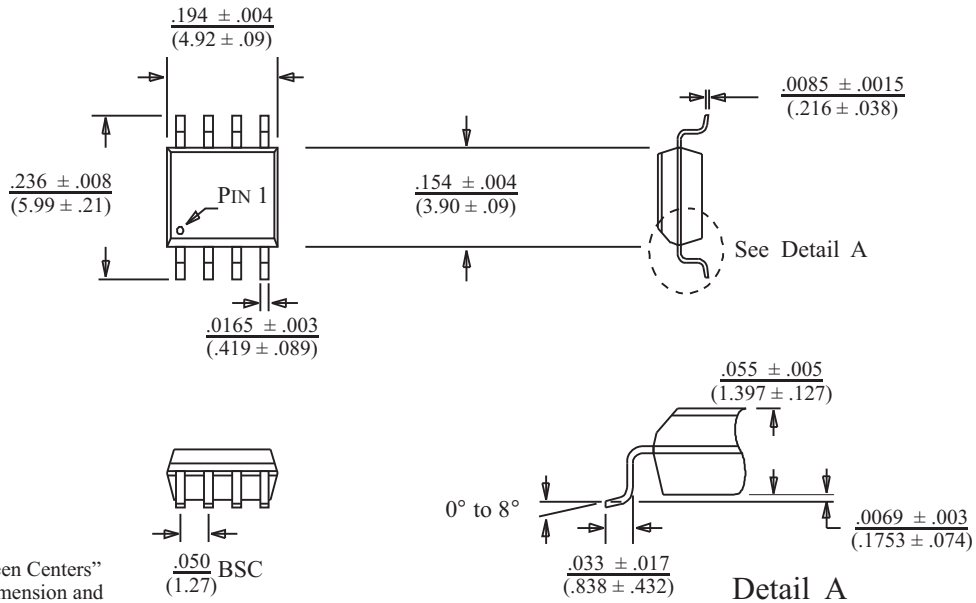

8-PIN CERDIP

inches (millimeters)
Package Type: 8D

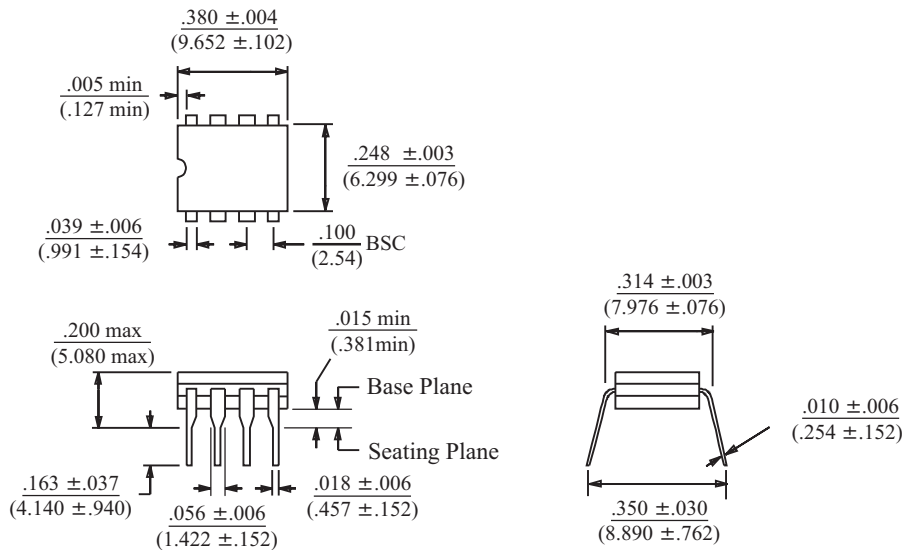

8-PIN PLASTIC DIP

inches (millimeters)

Package Type: 8P

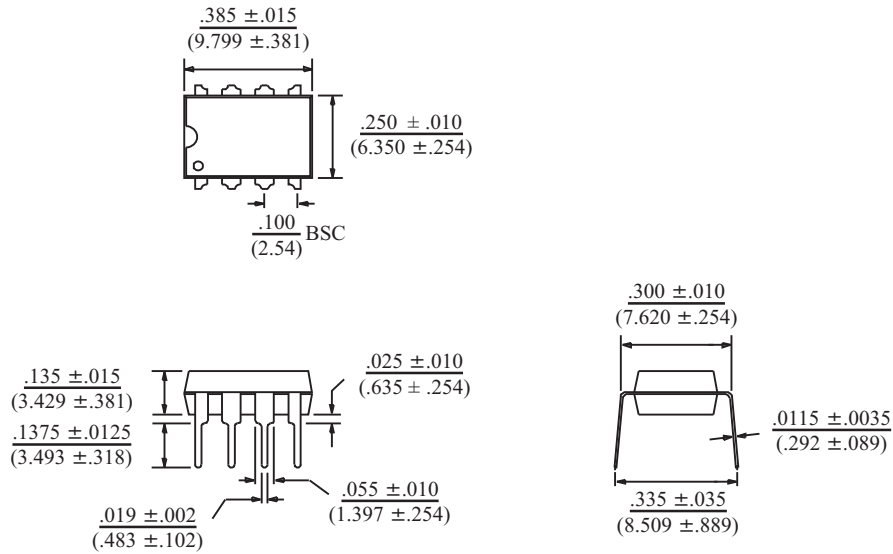

BSC = "Basic Spacing between Centers" is theoretical true position dimension and has no tolerance. (JEDEC Standard 95)

16-PIN PLASTIC CHIP-SCALE PACKAGE

millimeters

Package Type: 16PCS

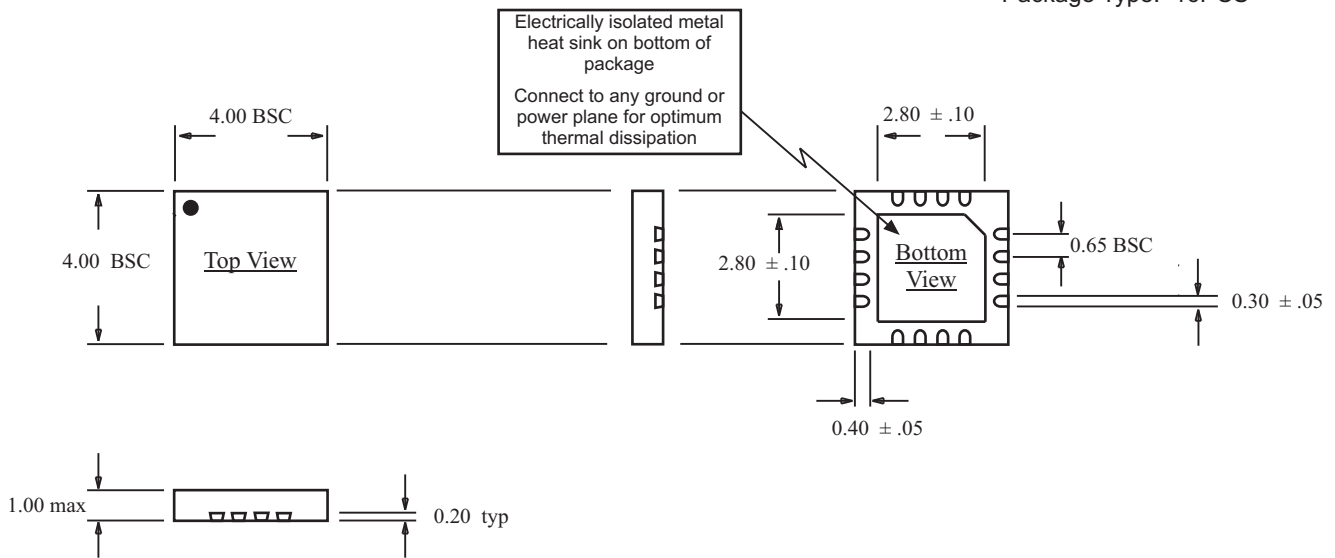

BSC = "Basic Spacing between Centers" is theoretical true position dimension and has no tolerance. (JEDEC Standard 95)