

March 2012

GENERAL DESCRIPTION

The HI-485x devices are slew-rated controlled TIA-485/TIA-422-B and ISO 8482:1993 compliant transceivers with extended power-supply, temperature and receiver common-mode range for avionic and industrial control applications. The devices can operate over an extended supply (3.0V to 5.5V) and temperature (-55°C to 125°C) range. The receiver input common-mode range of [-15, 20]V, and ±24V for the half and full duplex configurations respectively is valid over the full supply and temperature specification. The HI-4850 has a half-duplex configuration, and the HI-4851 and HI-4852 are full-duplex. Slew rates are optimized for data rates below 5 Mbps. The drivers slew-rate control and pre-emphasis reduces high-frequency components in the output signal transitions and also compensates for impedance mismatch. These features provide optimum EMI and jitter performance, essential in EMI sensitive environments and high-integrity data link applications such as in aerospace and industrial controls.

The devices deliver at least ± 1.50V (VDD=3.0V), and ± 2.45V (VDD= 4.5V) output levels at an extended temperature range of -55°C to +125°C into a differential load of 54Ω and 50pF.

The receiver offers true Fail-Safe operation, providing a guaranteed logic high on RO when the bus is open-circuit, short-circuit, or idle (terminated but not driven). The receiver's worst case minimum input resistance is at least 90KΩ, supporting up to 224 nodes

APPLICATIONS

- Extended Temperature Range RS-485/422 Networks
- Process Control and Factory Automation
- EMI Emission Sensitive Avionics
- Industrial Field Bus Networks
- Networks requiring extended common-mode range

Device Selection Table			
Part Number	Half/Full Duplex	Data Rate (Mbps)*	Package
HI-4850	Half	≤ 5.0	8-pin SOIC
HI-4851	Full	≤ 5.0	8-pin SOIC
HI-4852	Full	≤ 5.0	14-pin SOIC 16-pin QFN

* For RS-485 Transceivers optimized for data rates up to 20Mbps please refer to the HI-4853 data sheet.

FEATURES

- Slew Rate Control and Pre-Emphasis for superior EMI
- Extended Power Supply Operating Range 3.0V to 5.5V
- Extended Receiver Common-Mode Range:
 - -15.0V to 20.0V Half-Duplex
 - ±24V Full-Duplex
- ESD Protection
 - 16KV HBM (Bus Pins)
 - 8KV HBM (Logic Pins)
- 5 Mbps Data Rate up to 100 ft. CAT-5 UTP
- 2 Mbps Data Rate up to 1000 ft. CAT-5 UTP
- Current Limiting Protection
- Extended Temperature Range -55°C to 125°C
- Industry Standard 75176 Pin-out

PIN CONFIGURATIONS (Top Views)

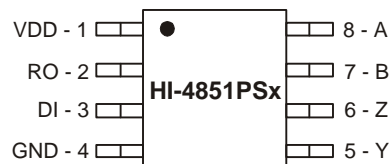
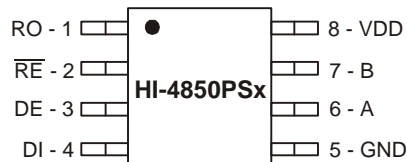

8-Pin Plastic SOIC package (Narrow Body)

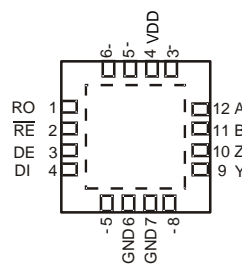

HI-4852PCx

16-pin 4mm x 4mm Chip-scale package

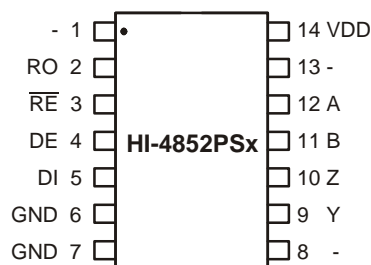

14-Pin Plastic SOIC package (Narrow Body)

PIN DESCRIPTIONS

SIGNAL	FUNCTION	DESCRIPTION
RO	OUTPUT	Receiver Output. If $V_{ID} \geq -50\text{mV}$, then RO is high. If $V_{ID} < -150\text{mV}$ then RO is low. If the bus is shorted, open or terminated but not driven by another terminal, RO will be high.
$\overline{\text{RE}}$	INPUT	Receiver Enable. $\overline{\text{RE}} = \text{Low}$ enables the receiver. $\overline{\text{RE}} = \text{High}$ forces the receiver output (RO) into a high impedance state. Internal 450K Ω pull-up resistor
DE	INPUT	Driver Enable. DE = high enables the driver. DE = low will force the driver output into a high impedance state and the device will function as a line receiver if $\overline{\text{RE}}$ is also low. Internal 450K Ω pull-up resistor
DI	INPUT	Driver Input. Forces the logic state of the Driver's output, if Driver is enabled. Internal 450K Ω pull-up resistor
GND	POWER	Chip ground, 0V Supply
A, Y	ANALOG I/O	Non-inverting Receiver Input / Driver Output.
B, Z	ANALOG I/O	Inverting Receiver Input / Driver Output.
VDD	POWER	Positive Supply: $3.0\text{V} \leq \text{VDD} \leq 5.5\text{V}$

TX FUNCTION TABLE

TRANSMITTING					
INPUTS			LINE CONDITION	OUTPUTS	
$\overline{\text{RE}}$	DE	DI		B	A
X	1	1	Transmit logic high	0	1
X	1	0	Transmit logic low	1	0
0	0	X	Disable	Hi-Z	Hi-Z
1	0	X	Shutdown	Hi-Z	Hi-Z

RX FUNCTION TABLE

RECEIVING				
INPUTS		BUS PINS $V_{ID} = V_A - V_B$	OUTPUT RO	OPERATION
$\overline{\text{RE}}$	DE			
0	0	$-150\text{mV} < V_{ID} < -50\text{mV}$	X	Undefined Input
0	0	$-50\text{mV} \leq V_{ID}$	1	Receiver logic high
0	0	$V_{ID} \leq -150\text{mV}$	0	Receiver logic low
0	0	Open or Shorted	1	Default
0	0	Idle and terminated	1	Default
1	1	X	Hi-Z	Disabled
1	0	X	Hi-Z	Shutdown

Typical Operating Circuit

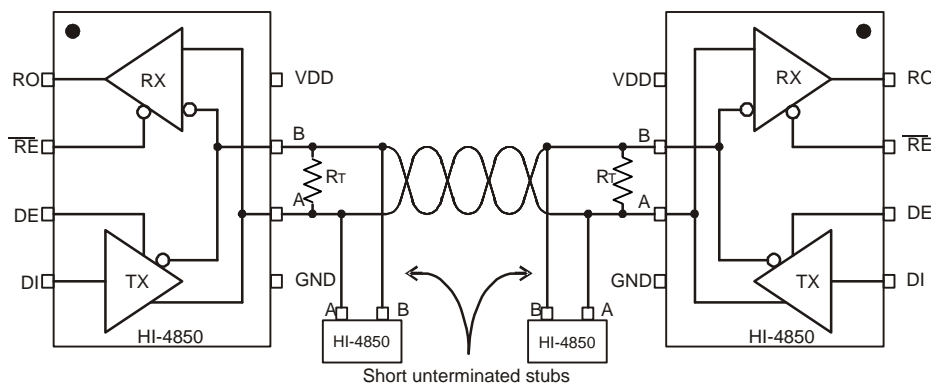

Figure 1 - Typical half-duplex configuration

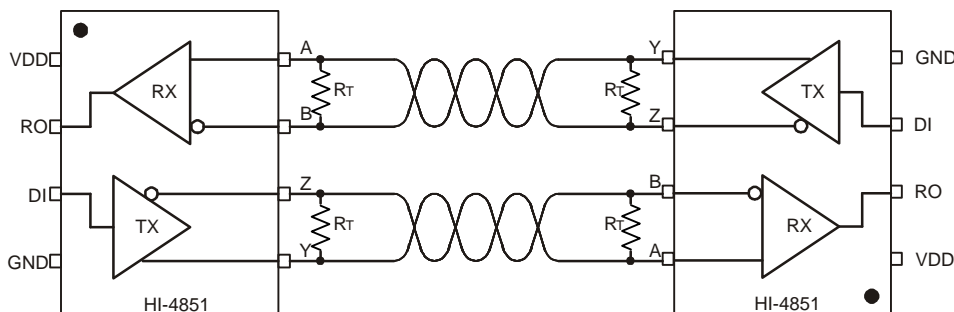

Figure 2 - Typical full-duplex 8-pin configuration

ABSOLUTE MAXIMUM RATINGS

(Voltages referenced to GND = 0V)

Supply Voltage, VDD:.....7 V	Operating Temperature Range:(Industrial).....-40°C to +85°C (Hi-Temp).....-55°C to +125°C
Control Input Currents:-100mA to 100mA	
Control Input Voltages:.....-0.5V to VDD + 0.5V	Internal Power Dissipation:.....900mW
Digital Input Voltages (DI, DE, RE):.....-0.5V to VDD + 0.5V	
Bus Voltage (AY, BZ):.....±25V	Storage Temperature Range:-65°C to +150°C
Digital Output Voltage (RO):.....-0.5V to V + 0.5V	
Short-Circuit Duration, Driver (V: ±15V).....∞	Soldering Temperature: (Ceramic).....60 sec. at +300°C (Plastic - leads).....10 sec. at +280°C (Plastic - body).....+260°C Max.
ESD (Human Body Model):	
AY, BZ, VDD, GND pins:.....±16KV DI, DE, RE, RO pins:.....±8KV	

NOTE: Stresses above those listed under "Absolute Maximum Ratings" may cause permanent damage to the device. These are stress ratings only. Functional operation of the device at these or any other conditions above those indicated in the operational sections of the specifications is not implied. Exposure to absolute maximum rating conditions for extended periods may affect device reliability.

SPECIFIED OPERATING CONDITIONS

PARAMETERS	SYMBOL	CONDITIONS	LIMITS			UNIT
			MIN	TYP	MAX	
Supply Voltage	V _{DD}		3.0	3.3 / 5.0	5.5	V
Temperature	T		-55		125	°C
TX Common-Mode Bus Loading	V _{OCM}	See Figure 4	-7		12	V
RX Input Common-Mode Voltage	V _{ICM}	Half-Duplex	-16		20	V
Differential Load Resistance	R _L		54	60	∞	Ω
Differential Load Capacitance	C _L			100		pF
Digital Input High Voltage	V _{IH}	DE, DI, RE	70			%V _{DD}
Digital Input Low Voltage	V _{IL}	DE, DI, RE			30	%V _{DD}
Digital Input Current high	I _{IH}	DE, DI, V _{IH} = V _{DD}			1	μA
Digital Input Pull-Down Current	I _{PD}	RE, V _{IH} = V _{DD}	6		13	μA
Digital Input Current low	I _{IL}	RE, V _{IH} = 0	-1			μA
Digital Input Pull-Up Current	I _{PU}	DE, DI, V _{IH} = 0V	-13		-6	μA

DRIVER DC ELECTRICAL CHARACTERISTICS

VDD = 3.0V to 3.6V or 4.5V to 5.5V; T = -55°C to 125°C; MIN and MAX values are at range boundaries

PARAMETER	SYMBOL	CONDITIONS	FIGURE	VDD = 3.3V ± 10%			VDD = 5.0V ± 10%			UNIT
				MIN	TYP	MAX	MIN	TYP	MAX	
Differential Output Voltage with no load	V _{OD1}	R _L = ∞	3	V _{DD} - 0.1		V _{DD}	V _{DD} - 0.1		V _{DD}	V
Differential Output Voltage into load with no common-mode voltage	V _{OD2}	R _L = 54Ω, C _L = 50pF	3	1.5		3.0	2.45		4.0	V
Differential Output Voltage into load with applied common-mode voltage	V _{OD3}	-7V ≤ V _{OCM} ≤ 12V T _A = 25°C	4	1.5		3.0	2.45		4.0	V
Differential Output Over/Under Shoot						5.5			3.2	%V _{OD}
Change in Differential Output Voltage between logic states	ΔV _{OD}	R _L = 54Ω, C _L = 50pF	3	-125		125	-125		125	mV
Output Common-Mode Voltage	V _{OCM}	R _L = 54Ω, C _L = 50pF	4	1.40	1.60	2.0	2.15	2.45	3.0	V
Change in output Common-Mode Voltage between logic states	ΔV _{OCM}	R _L = 54Ω, C _L = 50pF	4	-125		125	-150		150	mV
Bus Pin Leakage Current (High-Z Power On)	I _{OHZ1}	DE=0, -15V ≤ V _{OCM} ≤ 15V DE=0, -12V ≤ V _{OCM} ≤ 15V		-200		200	-200		200	μA
Bus Pin Leakage Current (Power Off)	I _{OHZ2}	V _{OCM} = ±15V		-200		200	-200		200	μA
Peak Short Circuit Current	I _{SCP}	DE = V _{DD} , Bus Pin = ±15		-230		230	-250		250	mA
Steady State Short Circuit Current	I _{SC}	DE = V _{DD} , Bus Pin = ±15		0		50	0		50	μA
Differential Output Capacitance	C _{OD}	DE = 0				16			16	pF
Static Supply Current	I _{DD}	DE=V _{DD} , RE=0, R _L =∞			8	10		10	12	mA
Supply Current (Shutdown)	I _{DDQ}	DE=0, RE=V _{DD} , R _L =∞			90	110		100	400	μA

DRIVER SWITCHING CHARACTERISTICS

VDD = 3.0V - 3.6V or 4.5V - 5.5V as noted , Operating temperature range.

PARAMETER	SYMBOL	CONDITIONS	FIGURE	VDD = 3.3V ± 10%			VDD = 5.0V ± 10%			UNIT
				MIN	TYP	MAX	MIN	TYP	MAX	
Propagation Delay Low - to - High	tPDR	RL = 54Ω, CL=50pF	5 & 6	110	145	200	108	150	205	ns
Propagation Delay High - to - Low	tPDF	RL = 54Ω, CL=50pF	5 & 6	110	145	200	108	150	205	ns
Differential Rise Time	tr	RL = 54Ω, CL=50pF	5 & 6	90	105	120	115	135	155	ns
Differential Fall Time	tf	RL = 54Ω, CL=50pF	5 & 6	90	105	120	115	135	125	ns
Output Pulse Skew	tMSK	RL = 54Ω, CL=50pF	5 & 6		2	8		2	8	ns
Driver Enable to Output High	tZH	RL = 500Ω, CL=50pF	7		95	120		90	117	ns
Driver Enable to output Low	tZL	RL = 500Ω, CL=50pF	7		95	120		90	117	ns
Driver Disable from Output High	tHZ	RL = 500Ω, CL=50pF	7		20	33		18	30	ns
Driver Disable from Output Low	tLZ	RL = 500Ω, CL=50pF	7		20	33		18	30	ns
Shutdown to Active Output Delay	tON	RL = 500Ω, CL=50pF	7			10			10	µs
Shutdown Delay	tOFF					10			10	µs

RECEIVER DC ELECTRICAL CHARACTERISTICS

VDD = 3.0V - 3.6V or 4.5V - 5.5V as noted , Operating temperature range.

PARAMETER	SYMBOL	CONDITIONS	FIGURE	VDD = 3.3V ± 10%			VDD = 5.0V ± 10%			UNIT
				MIN	TYP	MAX	MIN	TYP	MAX	
Differential Input Threshold Voltage	VTH	-15 ≤ VICM ≤ +20		-200	-100	-50	-200	-100	-50	mV mV
Input Hysteresis	VHYS	VICM = 0V		17	28	33	17	28	33	mV
Input Resistance	RIN	-15 ≤ VICM ≤ +20		80	92		80	92		KΩ KΩ
RO Output High Level	VOH	VICM = +200mV IOUT = -3.0mA		90%			90%			VDD
RO Output Low Level	VOL	VICM = -200mV IOUT = +3.0mA				10%			10%	VDD
RO Output Hi-Z Leakage Current	IOZH	0V ≤ VRO ≤ VDD		-1		1	-1		1	µA

RECEIVER SWITCHING CHARACTERISTICS

VDD = 3.0V - 3.6V or 4.5V - 5.5V as noted , Operating temperature range.

PARAMETER	SYMBOL	CONDITIONS	FIGURE	VDD = 3.3V ± 10%			VDD = 5.0V ± 10%			UNIT
				MIN	TYP	MAX	MIN	TYP	MAX	
Propagation Delay Low - to - High	trPDR	VID = +1.5V, CL=15pF	8	20	26	32	20	26	32	ns
Propagation Delay High - to - Low	trPDF	VID = -1.5V, CL=15pF	8	20	26	32	20	26	32	ns
RO Output Rise Time	trR	VID = +1.5V, CL=15pF	8	1.1	1.9	3.3	1.1	1.9	3.3	ns
RO Output Fall Time	trF	VID = -1.5V, CL=15pF	8	1.1	1.9	3.3	1.1	1.9	3.3	ns
Output Pulse Skew	trMSK	VID = +1.5V, CL=15pF	8		0.8	1.6		0.8	1.6	ns
Receiver Enable to RO Output High	trZH	RL = 1KΩ, CL=15pF	9		12	16		12	16	ns
Receiver Enable to output Low	trZL	RL = 1KΩ, CL=15pF	9		12	16		12	16	ns
Receiver Disable from Output High	trHZ	RL = 1KΩ, CL=15pF	9		6	10		6	10	ns
Receiver Disable from Output Low	trLZ	RL = 1KΩ, CL=15pF	9		6	10		6	10	ns
Shutdown to RO Active Output Delay	tRON	RL = 1KΩ, CL=15pF	9			5			5	µs
Shutdown Delay to RO HiZ	tROFF	RL = 1KΩ, CL=15pF	9		60	100		60	100	ns

TEST CIRCUITS

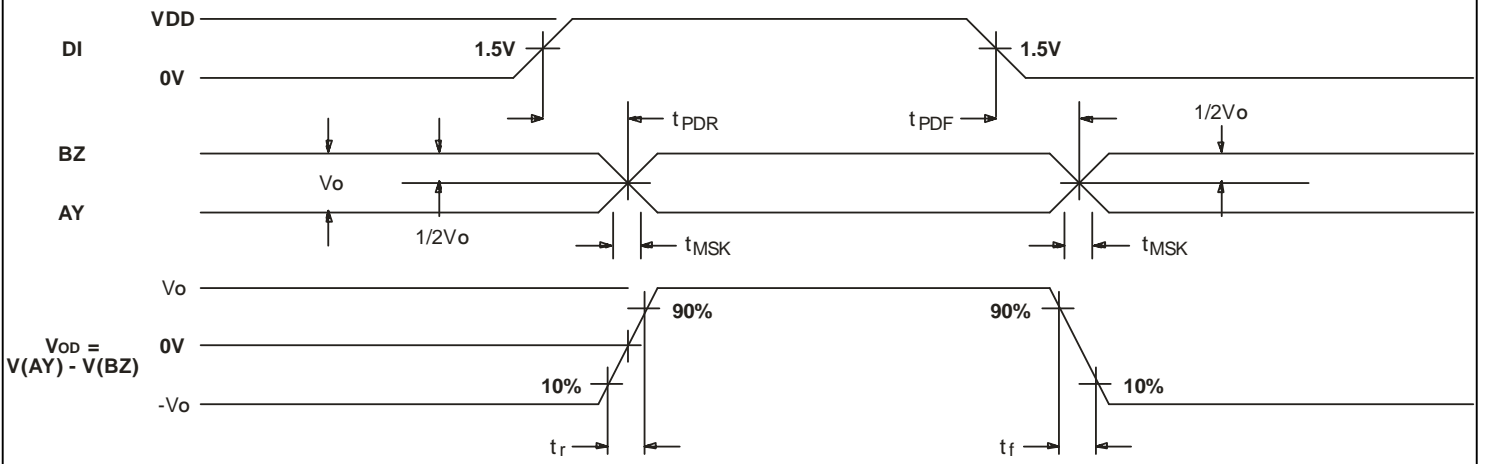
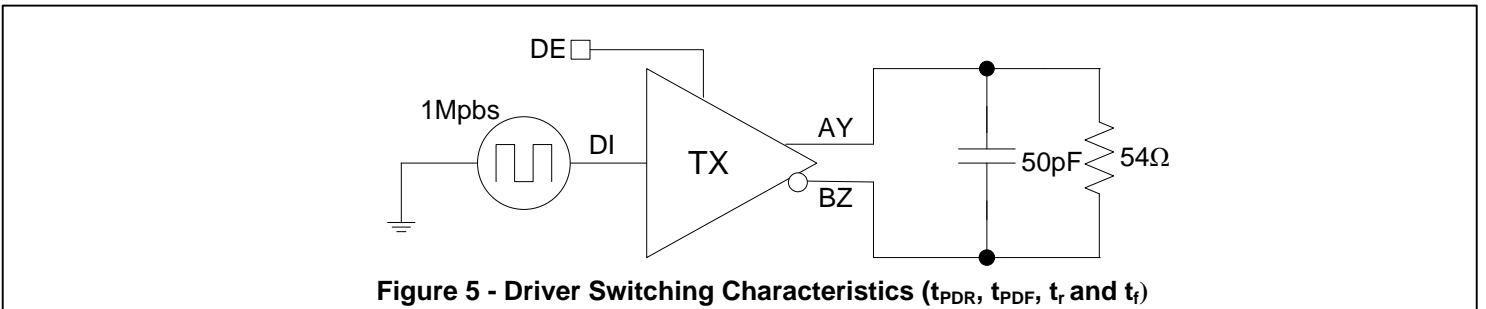
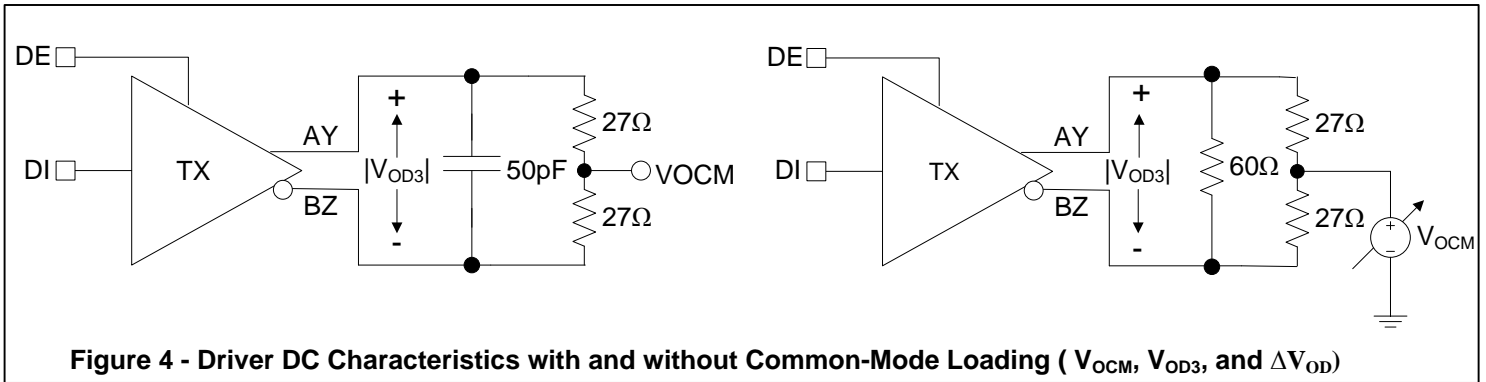
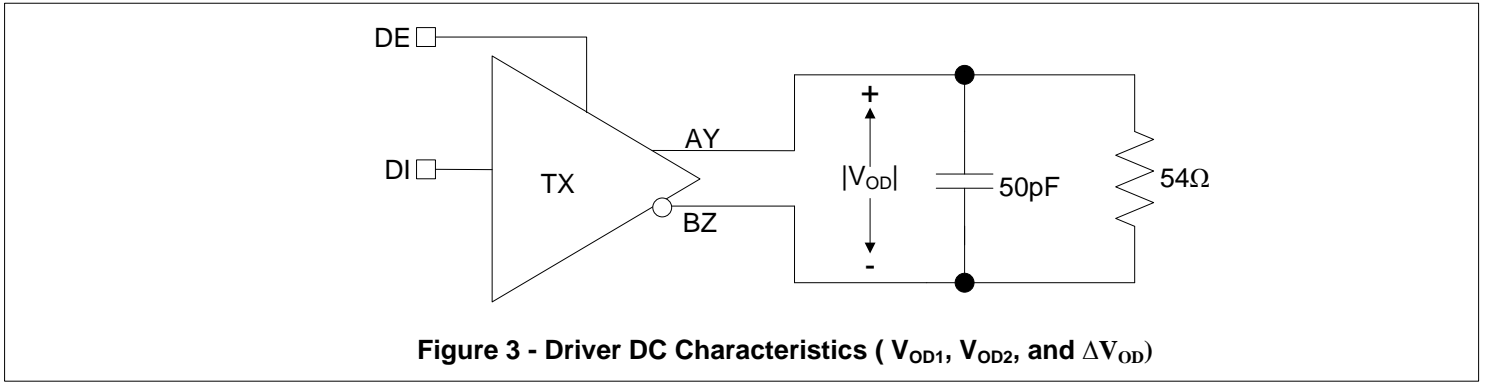

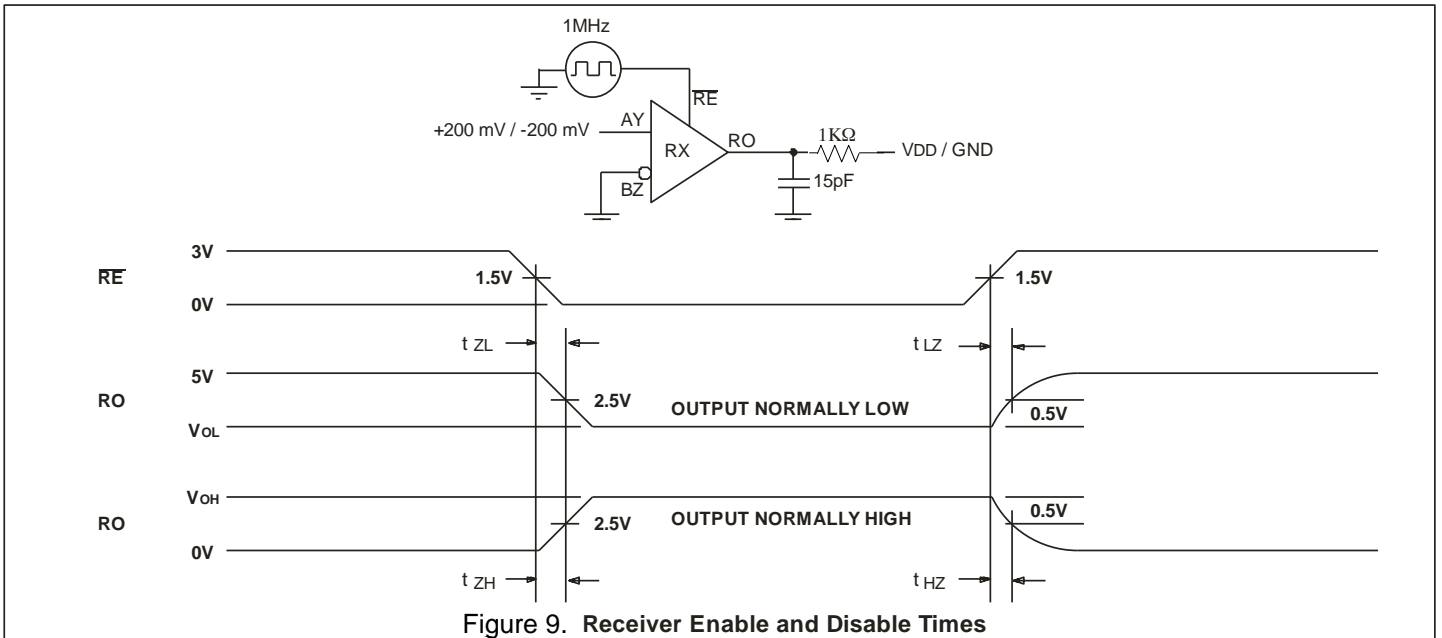
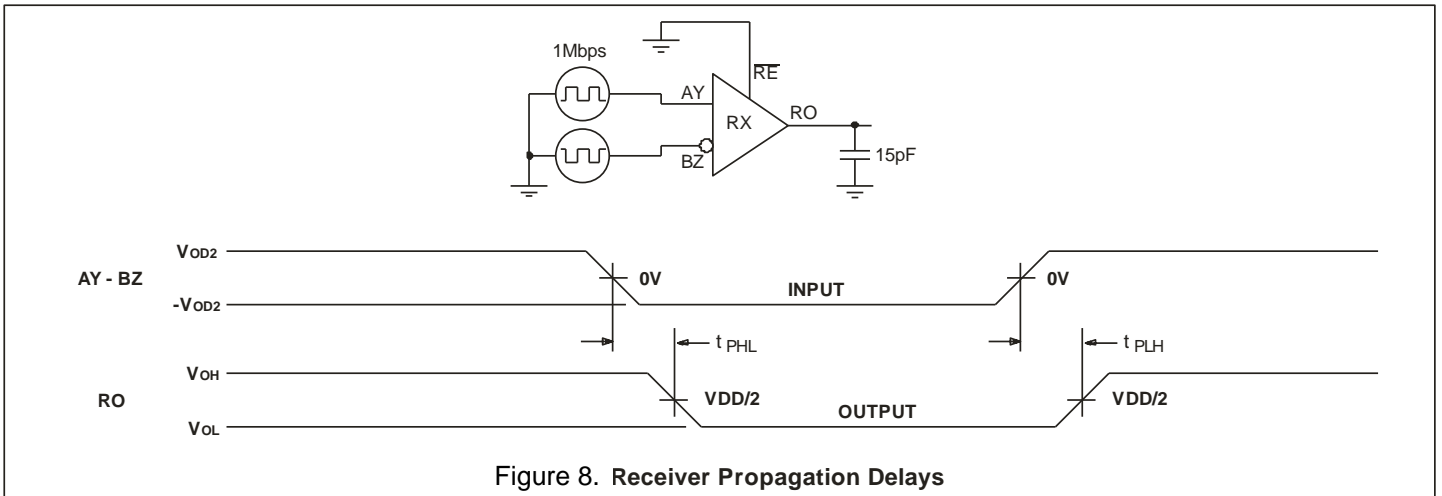
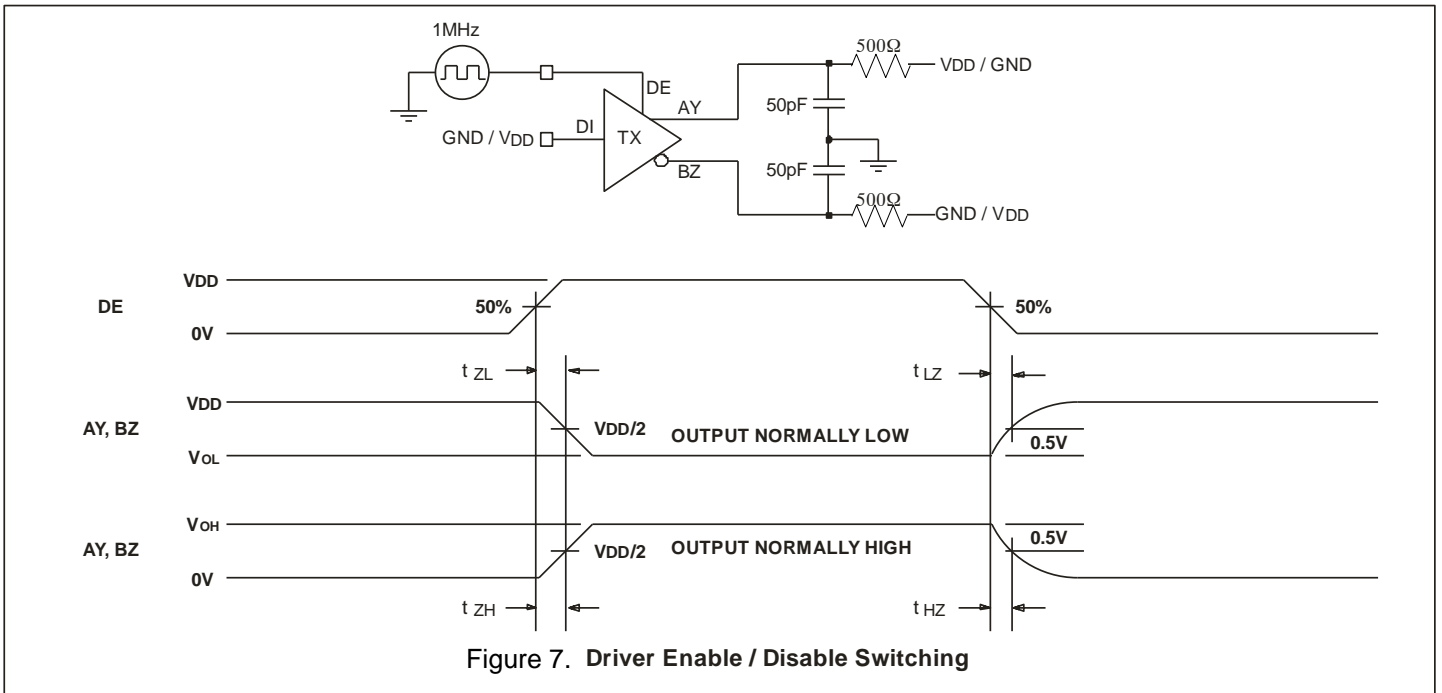

PERFORMANCE CHARACTERISTICS OVER SUPPLY AND TEMPERATURE
HI-4850/52

RX PROPAGATION DELAY vs. TEMPERATURE

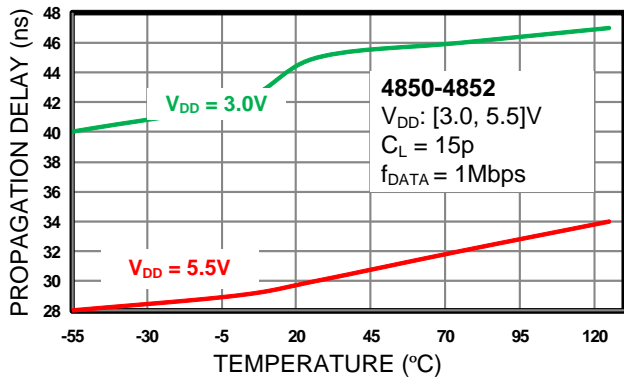

RX PROP DELAY vs. INPUT COMMON-MODE

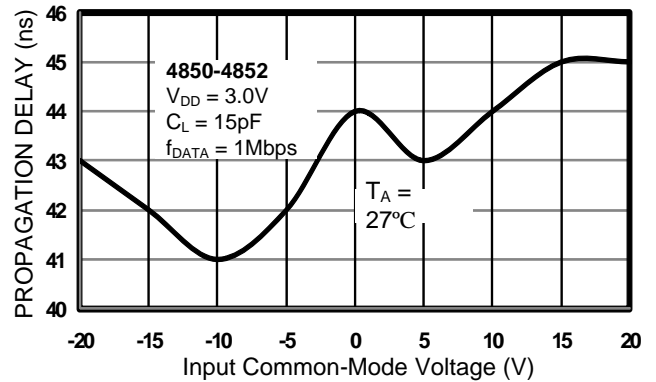

TX DIFFERENTIAL ZERO TO PEAK AMPLITUDE vs. TEMPERATURE

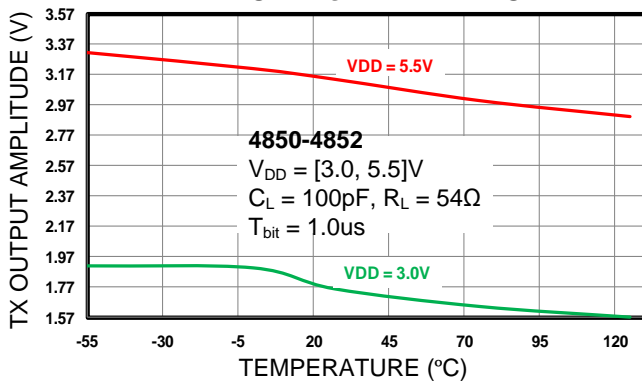

TX PROPAGATION DELAY vs. TEMPERATURE

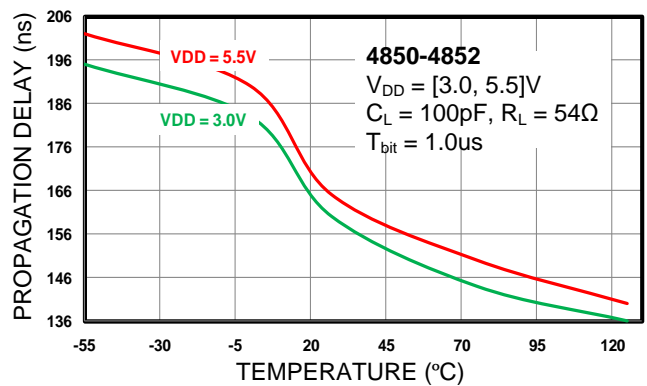

TX Rise/Fall Time vs. TEMPERATURE

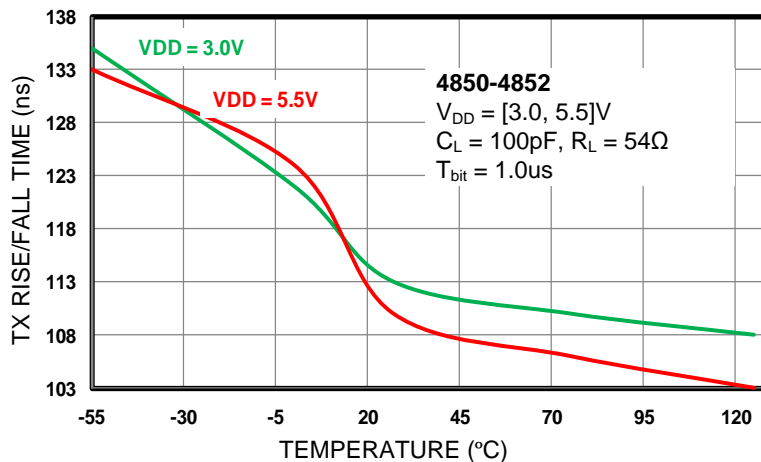

Full Duplex Receiver Typical Performance Characteristics HI-4851/52

**RX Extended Common-Mode Range:
Minimum Supply, Maximum Common-Mode**

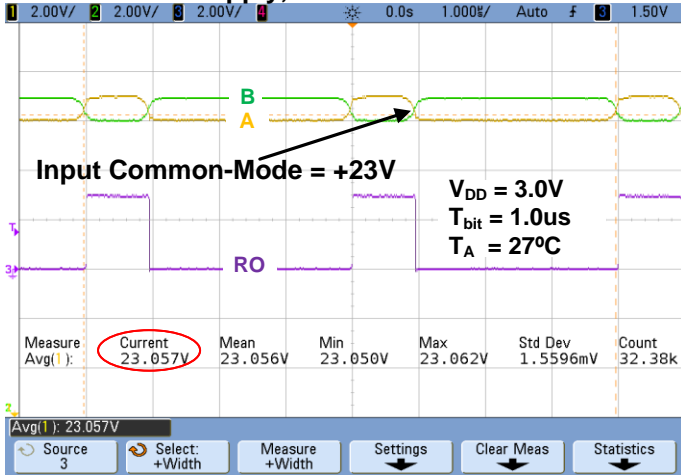

**RX Extended Common-Mode Range:
Minimum Supply, Minimum Common-Mode**

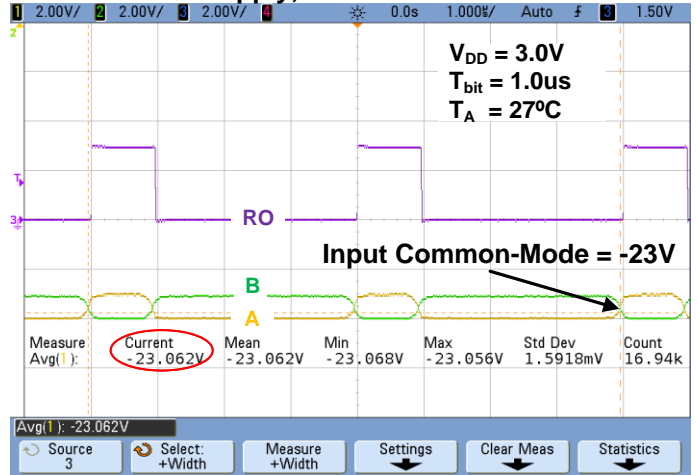

**RX Extended Common-Mode Range:
Maximum Supply, Maximum Input-CM**

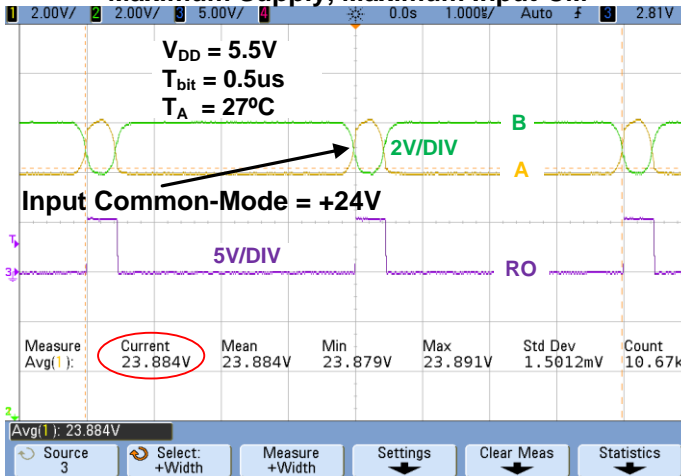

**RX Extended Common-Mode Range:
Maximum Supply, Minimum Common-Mode**

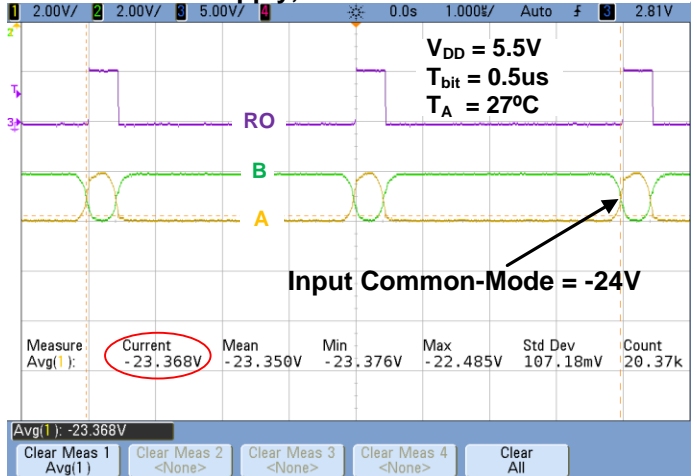

1Mbps Data Pulse Over 1000ft CAT-5 UTP

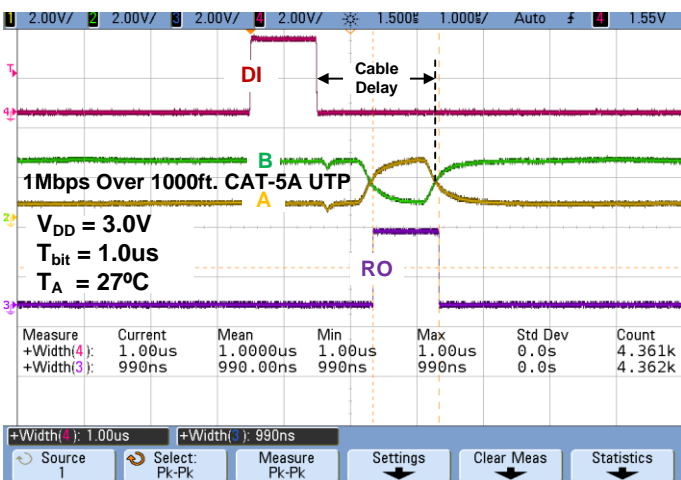

2Mbps Data Pulse Over 1000ft CAT-5 UTP

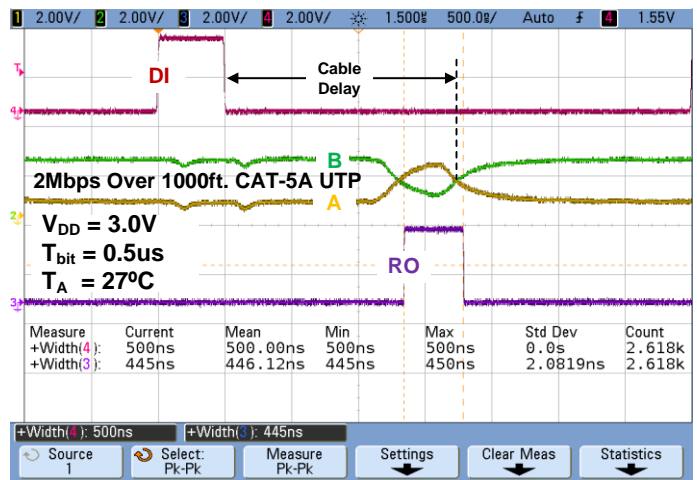

TYPICAL TRANCEIVER PERFORMANCE CHARACTERISTICS

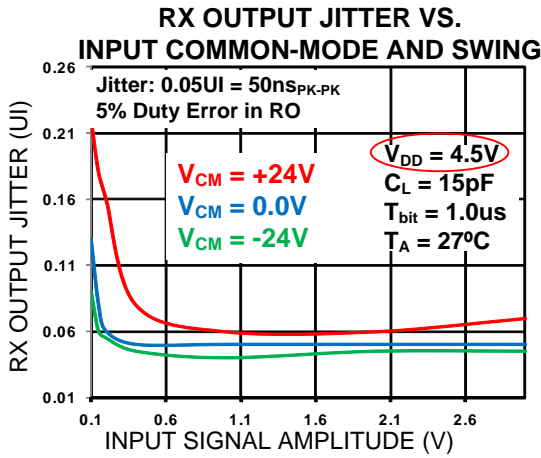

HI-4851/52

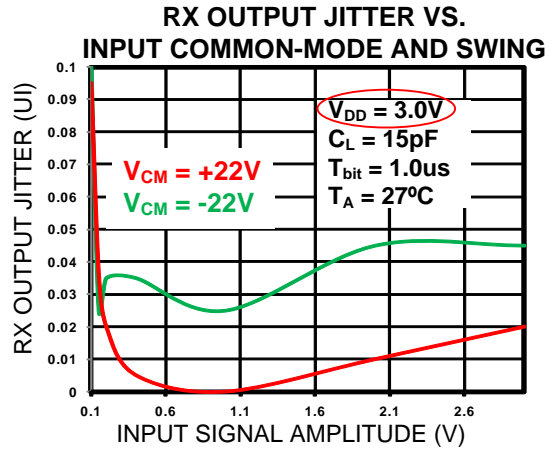

HI-4851/52

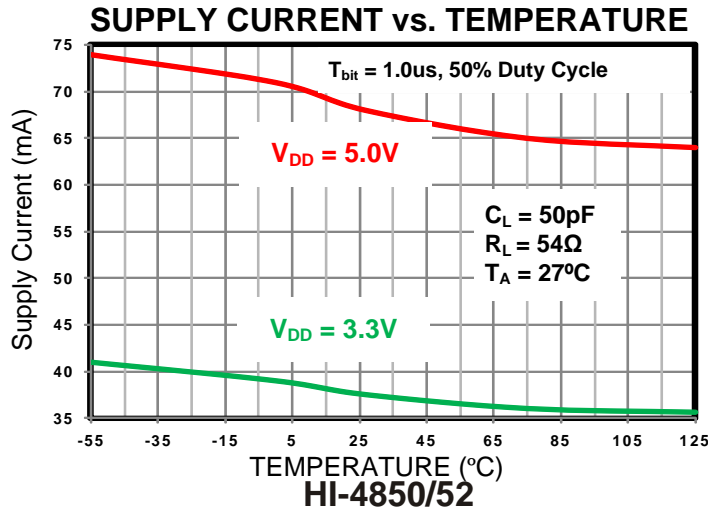

HI-4850/52

Typical TX/RX Propagation Delay @ 3.3V, 27 °C

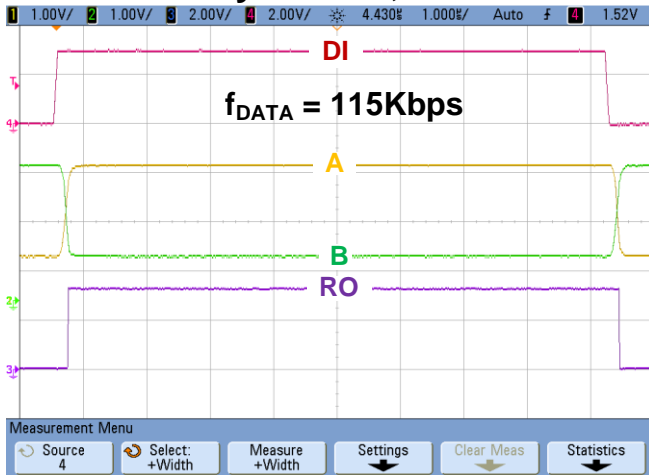

HI-4850/52

Typical TX Rise/Fall Time Max Load @ 3.3V, 27 °C

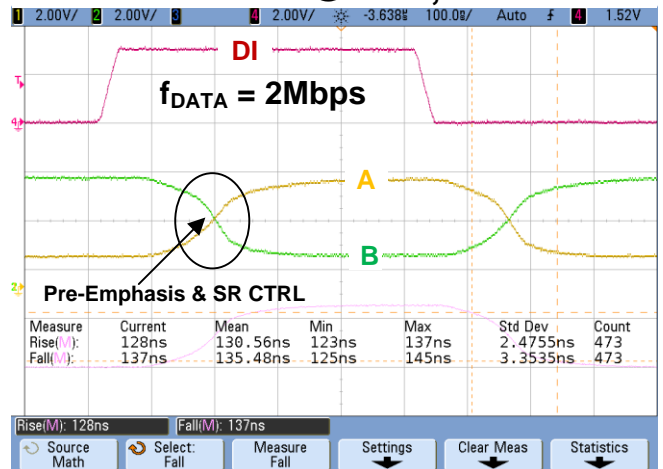

HI-4850/52

TYPICAL PERFORMANCE CHARACTERISTICS

HI-4850/52

TX Slew-Rate Controlled Output Characteristics:

VDD = 3.3V, f_{DATA} = 1Mbps, C_L < 1pF, R_L = ∞

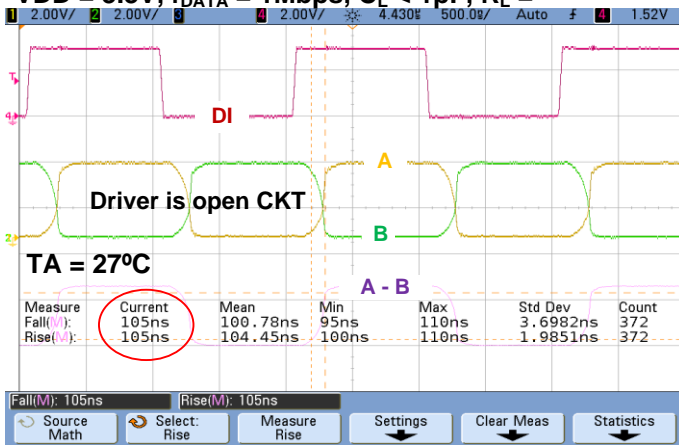

TX Slew-Rate Controlled Output Characteristics:

VDD = 3.3V, f_{DATA} = 1Mbps, C_L = 50pF, R_L = 54Ω

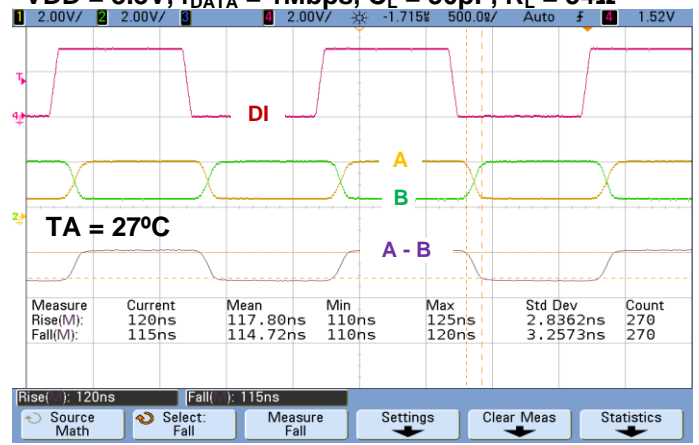

TX Low Speed Output Characteristics:

VDD = 3.3V, f_{DATA} = 115Kbps, C_L = 50pF, R_L = 54Ω

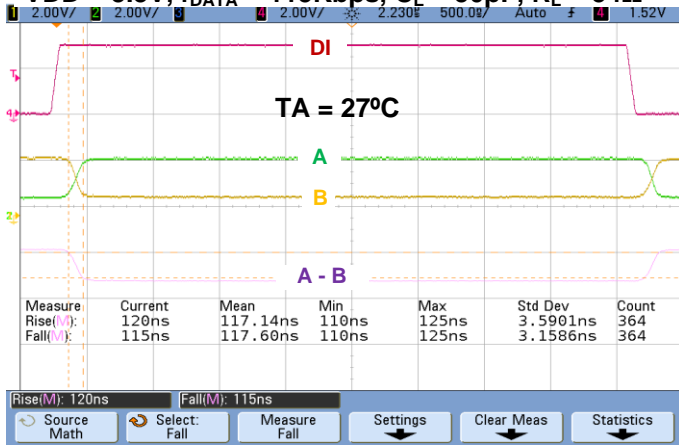

TX High Speed Output Characteristics:

VDD = 3.3V, f_{DATA} = 2Mbps, C_L = 50pF, R_L = 54Ω

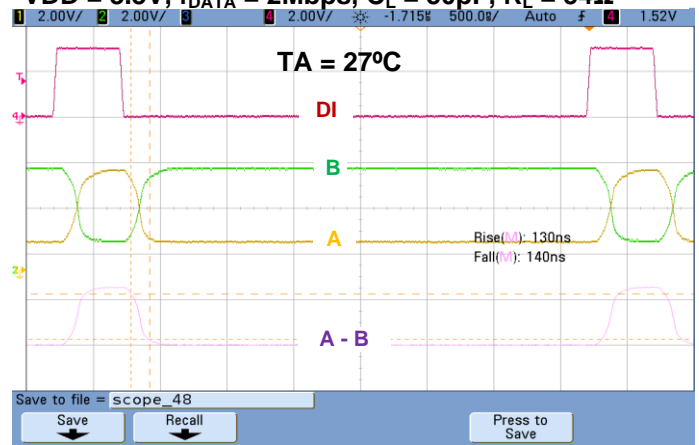

TX / RX Propagation Delay:

VDD = 3.3V, f_{DATA} = 1Mbps, C_L = 50pF, R_L = 54Ω

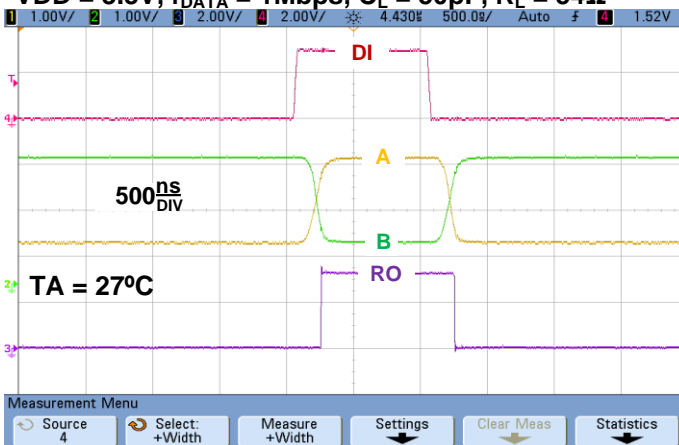

TX / RX Propagation Delay:

VDD = 3.3V, f_{DATA} = 2Mbps, C_L = 50pF, R_L = 54Ω

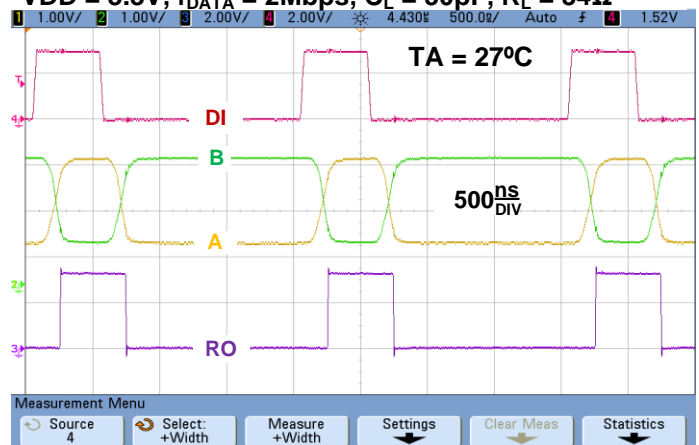

ORDERING INFORMATION

HI - 485x xx x x

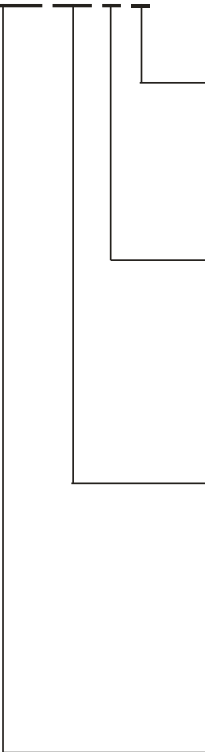

PART NUMBER	LEAD FINISH
Blank	Tin / Lead (Sn / Pb) Solder
F	100% Matte Tin (Pb-free, RoHS compliant)

PART NUMBER	TEMPERATURE RANGE	FLOW	BURN IN
I	-40°C TO +85°C	I	NO
T	-55°C TO +125°C	T	NO
M	-55°C TO +125°C	M	YES

PART NUMBER	PACKAGE DESCRIPTION
PC	16 PIN PLASTIC 4 x 4 mm CHIP SCALE (16PCS) (HI-4852 only. No M-flow)
PS	8 PIN PLASTIC NARROW BODY SOIC (8HN) (HI-4850, HI-4851)
PS	14 PIN PLASTIC NARROW BODY SOIC (14HN) (HI-4852 only)
CR	8 PIN Cerdip (8D) not available Pb-free (HI-4850, HI-4851)

PART NUMBER	FUNCTION
4850	HALF DUPLEX TRANSCEIVER
4851	FULL DUPLEX TRANSCEIVER ALWAYS ENABLED
4852	FULL DUPLEX TRANSCEIVER WITH ENABLE PINS

REVISION HISTORY

Revision	Date	Description of Change
DS4850, Rev New	10/12/2011	Initial Release
Rev. A	3/15/2012	Added characterization data. Fixed errors in V_{IL} and V_{IH} values.

8-PIN PLASTIC SMALL OUTLINE (SOIC) - NB
(Narrow Body)

inches (millimeters)

Package Type: 8HN

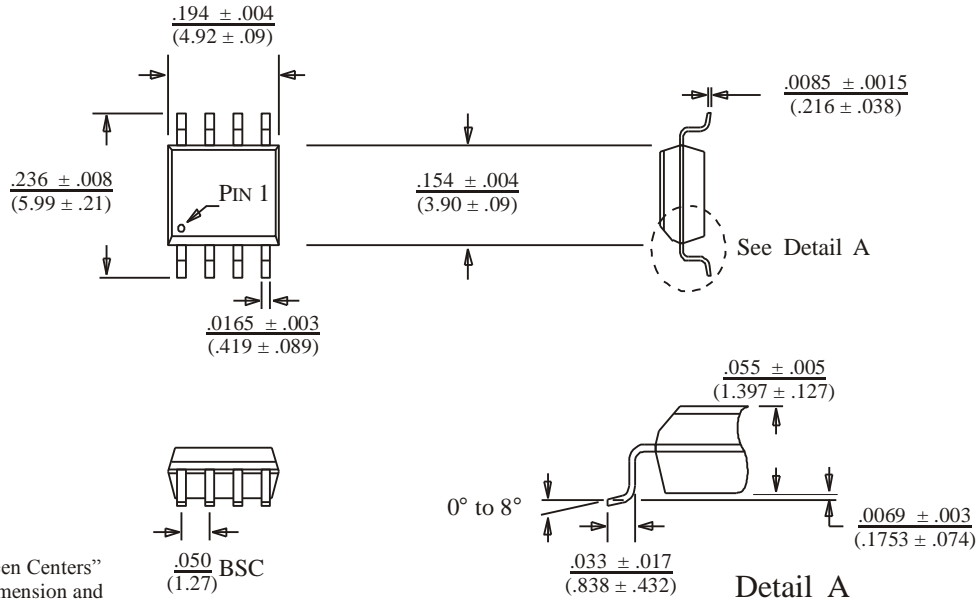

BSC = "Basic Spacing between Centers" is theoretical true position dimension and has no tolerance. (JEDEC Standard 95)

16-PIN PLASTIC CHIP-SCALE PACKAGE

millimeters

Package Type: 16PCS

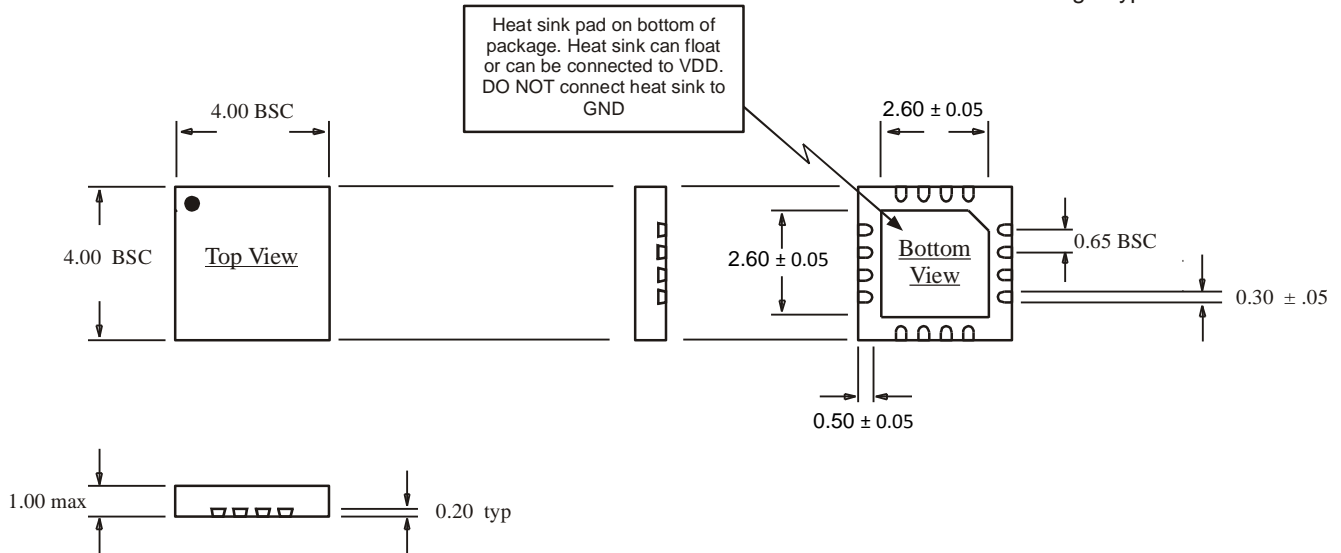

BSC = "Basic Spacing between Centers" is theoretical true position dimension and has no tolerance. (JEDEC Standard 95)

14-PIN PLASTIC SMALL OUTLINE (SOIC) - NB
(Narrow Body)

inches (millimeters)

Package Type: 14HN

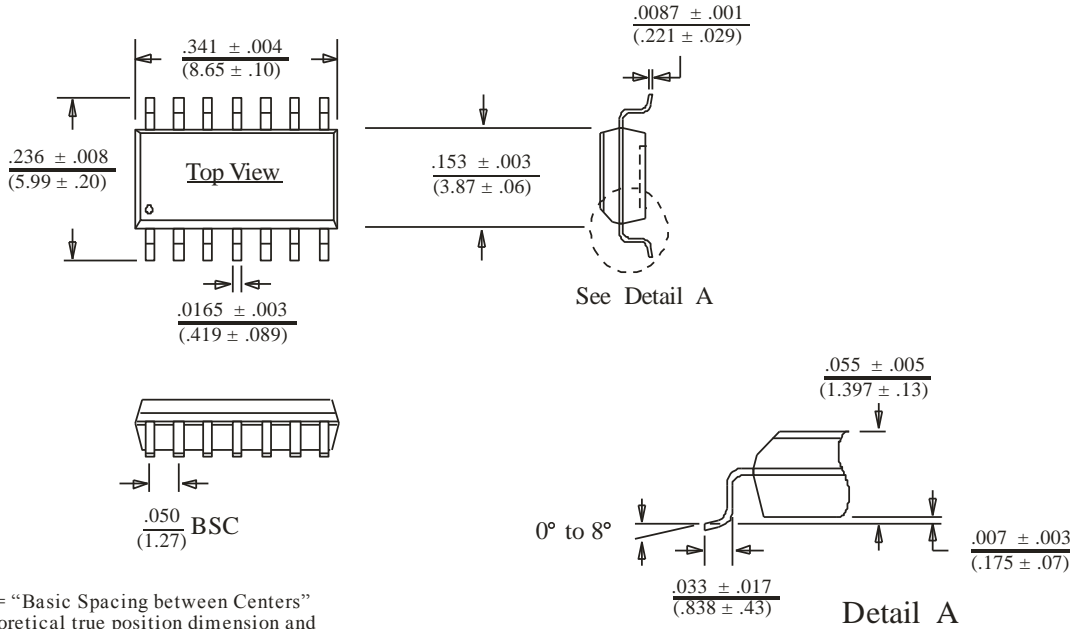

BSC = "Basic Spacing between Centers" is theoretical true position dimension and has no tolerance. (JEDEC Standard 95)

8-PIN CERDIP

inches (millimeters)

Package Type: 8D

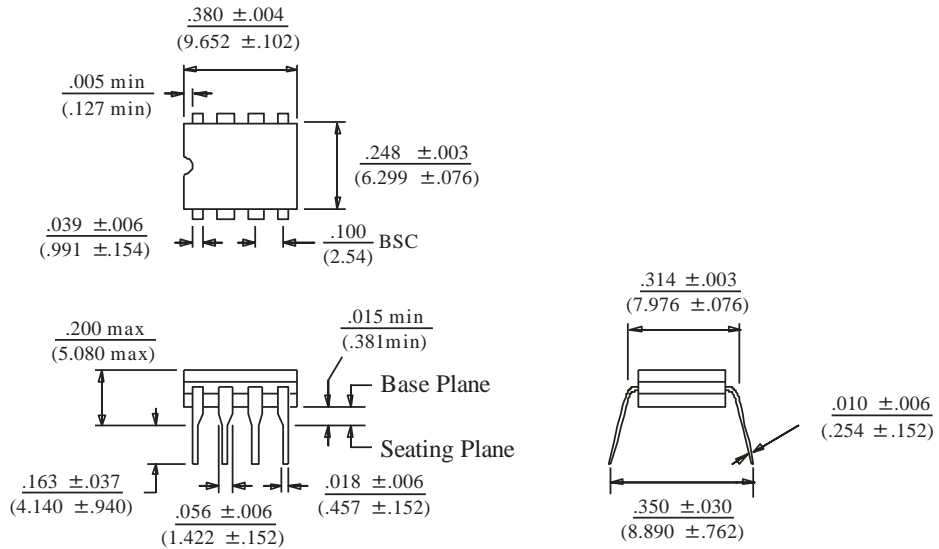

BSC = "Basic Spacing between Centers" is theoretical true position dimension and has no tolerance. (JEDEC Standard 95)