

December 2011

GENERAL DESCRIPTION

The HI-8190 is a quad analog CMOS switch fabricated with Silicon-on-Insulator (SOI) technology for latch-up free operation and maximum switch isolation. The switch voltages can range from bipolar $\pm 3.3V$ to $\pm 15V$ or single ended from 3.3V to 15V. The logic supply can range from 3.3V to 5.0V. The HI-8190 provides four each normally open switches when the switch control inputs are Low. The HI-8191 provides four each normally closed switches when the switch control inputs are Low. The HI-8192 provides a combination of two normally On and two normally Off switches. The limits of the operating range are defined by the $V+/V-$ bias voltage.

On-resistance of each switch depends upon only the VLOGIC selection. At 5V, R_{ON} ranges from 10Ω to 17Ω while at 3.3V supply R_{ON} ranges from 10Ω to 22Ω. Each switch is designed using back to back high voltage transistors. Switch transistors are symmetrical and conduct equally well in either direction. Signal range can run the full rails. Off leakages are very low (1 nA typical) and charge injection is less than 3 pC. Switch ESD tolerance is greater than 4 KV.

The Off state is achieved first before any On condition is applied. Switching times with a 3.3V VLOGIC supply are typically 35 ns to the On state and 20 ns to the Off state.

Industry-standard plastic package options include 16-pin TSSOP, SO, DIP and 16-pin QFN. Ceramic packaging is available on request. All three products are offered in both Industrial ($-40^{\circ}C$ to $+85^{\circ}C$) and extended ($-55^{\circ}C$ to $+125^{\circ}C$) temperature range options.

APPLICATIONS

- Data bus isolation
- Sample-and-Hold circuits
- Test Equipment
- Communications Systems
- Battery operated Systems
- PBX, PABX
- Audio Signal Routing
- Data Acquisition Systems
- xDSL Modems
- Avionics

FEATURES

- $\pm 3.3V$ to $\pm 15V$ CMOS analog switches
- Low R_{ON} : 12 Ω to 15 Ω typical
- Robust CMOS Silicon-on-Insulator (SOI) technology
- SOI switch isolation with 1nA typical Off leakage
- Superior ESD protection > 4KV HBM
- Fast switching time with break-before-make
- Low power
- Extended Temperature Range ($-55^{\circ}C$ to $+125^{\circ}C$)

PIN CONFIGURATIONS (Top Views)

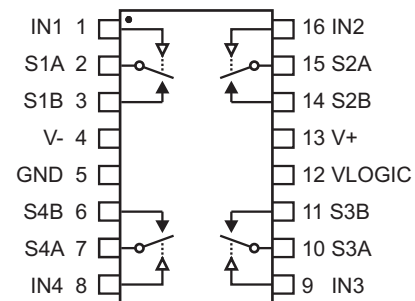

HI-8190PSx, HI-8190PDx
16-Pin SO or DIP package

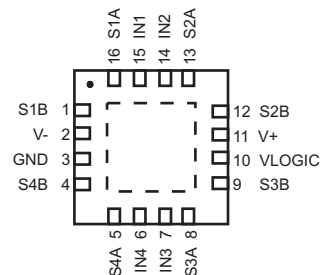

HI-8190PCx
16-pin 5mm x 5mm Chip-scale package

PRODUCT OPTIONS								
PART TYPE	IN1	Switch 1	IN2	Switch 2	IN3	Switch 3	IN4	Switch 4
HI-8190	0	Open	0	Open	0	Open	0	Open
	1	Closed	1	Closed	1	Closed	1	Closed
HI-8191	0	Closed	0	Closed	0	Closed	0	Closed
	1	Open	1	Open	1	Open	1	Open
HI-8192	0	Open	0	Closed	0	Closed	0	Open
	1	Closed	1	Open	1	Open	1	Closed

PIN DESCRIPTIONS

SIGNAL	FUNCTION	DESCRIPTION
IN1	Logic Input	HI-8190 and HI-8192 are normally Open when input Low
S1A	Switch Node	Switch 1 Node
S1B	Switch Node	Switch 1 Node
V-	Supply	Negative supply for Bipolar configuration. GND for Unipolar use
GND	Supply	Reference Ground
S4B	Switch Node	Switch 4 Node
S4A	Switch Node	Switch 4 Node
IN4	Logic Input	HI-8190 and HI-8192 are normally Open when input Low
IN3	Logic Input	HI-8191 and HI-8192 are normally Closed when input Low
S3A	Switch Node	Switch 3 Node
S3B	Switch Node	Switch 3 Node
VLOGIC	Supply	3.3V or 5.0V Logic supply
V+	Supply	Positive supply for Bipolar and Unipolar configurations
S2B	Switch Node	Switch 2 Node
S1B	Switch Node	Switch 2 Node
IN2	Logic input	HI-8191 and HI-8192 are normally Closed when input Low

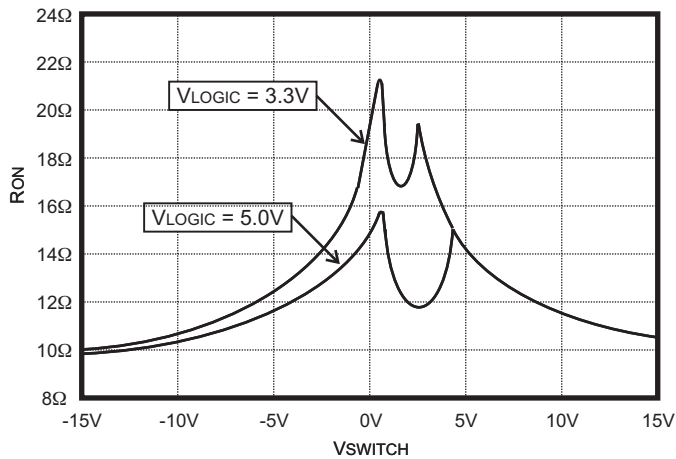

Typical RON as a function of VLOGIC and VSWITCH
(10mA switch current, 25°C)

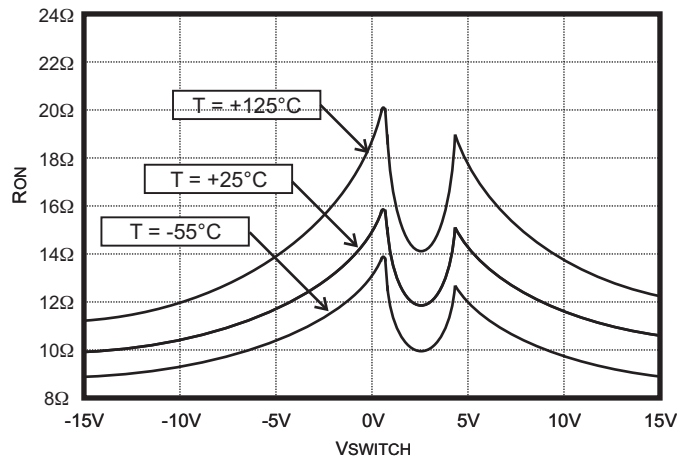

Typical RON as a function of VSWITCH and Temperature (10mA switch current)
VLOGIC = 5V

ABSOLUTE MAXIMUM RATINGS

(Voltages referenced to GND = 0V)

Supply Voltage, V+ :	16.5V	Continuous Power Dissipation (TA=70°C): SO Package (derate 6.7mW/°C above 70°C).....696mW Plastic DIP (derate 10.53 mw/°C above 70°C)842mW Thin QFN (derate 21.3mW/°C above 70°C)1702mW	
Supply Voltage, V-:.....	-16.5V		
Supply Voltage, V _{LOGIC}	5.5V		
Switch Current (either direction, DC):	20mA		
Peak Switch Current (1 ms pulse, 10% duty cycle max.):.....	100mA		
Digital Input Voltage (IN1-4):.....	-0.3V to V _{LOGIC} + 0.3V	Storage Temperature Range:	-65°C to +150°C
Operating Temperature Range: (Industrial).....	-40°C to +85°C	Soldering Temperature: (Ceramic).....60 sec. at +300°C (Plastic - leads).....10 sec. at +280°C (Plastic - body)+260°C Max.	
(Hi-Temp).....	-55°C to +125°C		
Maximum Junction Temperature	175°C		

NOTE: Stresses above those listed under "Absolute Maximum Ratings" may cause permanent damage to the device. These are stress ratings only. Functional operation of the device at these or any other conditions above those indicated in the operational sections of the specifications is not implied. Exposure to absolute maximum rating conditions for extended periods may affect device reliability.

ELECTRICAL CHARACTERISTICS

V+ = 15V, V- = -15V, GND = 0V. Operating temperature range (unless otherwise noted).

PARAMETER	SYMBOL	CONDITIONS	FIGURE	V _{LOGIC} = 3.3V			V _{LOGIC} = 5.0V			UNIT
				MIN	TYP	MAX	MIN	TYP	MAX	
SWITCH PARAMETERS										
Switch Signal Range	V _{RANGE}						-15		+15	V
Switch Resistance	R _{ON}	25°C, 10mA -55°C to +125°C, 10mA	1 1	10 8	22 26	10 8	17 20			Ω Ω
Leakage	I _{SWLEAK}	Switch voltage ± 15V, 25°C	2		5		5			nA
	I _{SWLEAK}	Switch voltage ± 15V, 125°	2		20		20			nA
	I _{SWLEAK}	Switch voltage ± 15V, -55°C	2		150		150			nA
LOGIC INPUTS										
Input High Voltage	V _{IH}			70			70			%V _{LOGIC}
Input Low Voltage	V _{IL}					30		30		%V _{LOGIC}
Input Current	I _{IN}	V _{IN} = 0V or V _{IN} =V _{LOGIC}		-0.5	0.5	-0.5	0.5			μA
SUPPLY										
V _{LOGIC} Current	I _{DD1}	Any state			0.5		0.5			μA
V+ Current	I _{DD2}	Any state			0.5		0.5			μA
V- Current	I _{EE}	Any state		-0.5		-0.5				μA
DYNAMIC PARAMETERS										
Turn On Time	T _{ON}	V+/- = ±10V, 25°C V _s = ±10V, -55°C to +125°C	3 3		55 75		35 55			ns ns
Turn Off time	T _{OFF}	V+/- = ±10V, 25°C V _s = ±10V, -55°C to +125°C	3 3		35 40		20 25			ns ns
Break-Before-Make Time	T _D	10V signal, 25°C 10V signal, -55°C to +125°C	4 4	4	8		4	8		ns ns
Charge Injection	Q	V _s =0V, R _s =0Ω, 25°C	5		4		4			pC
Off Isolation	R _R	f = 1 MHz, 25°C	6		65		65			dB
Crosstalk	C _R	f = 1 MHz, 25°C	7		90		90			dB
Capacitance	C _{OFF} C _{ON}	Switch Off, 25°C Switch On, 25°C	8 9		5 20		5 20			pF pF

TEST CIRCUITS

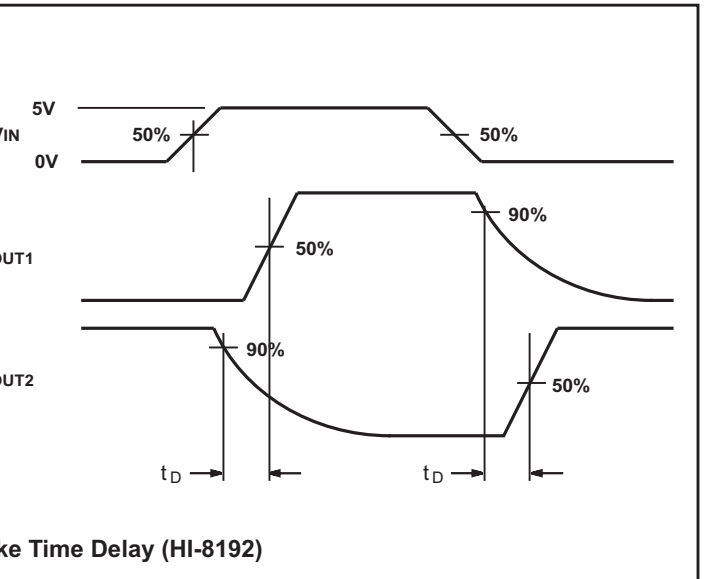
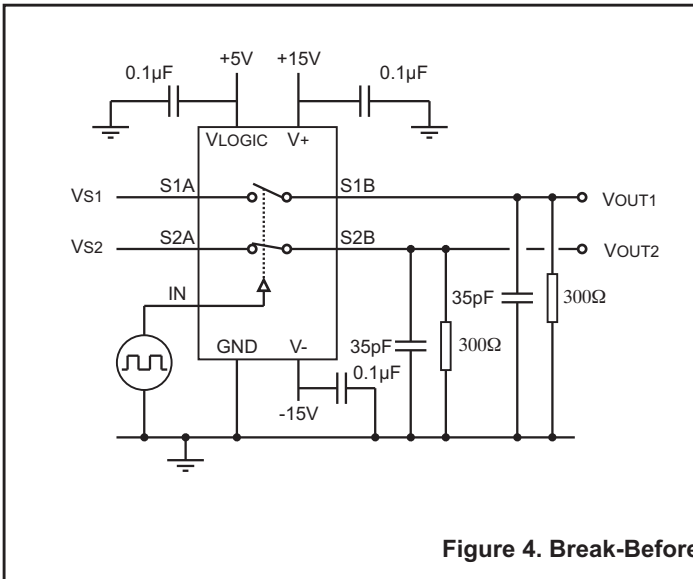
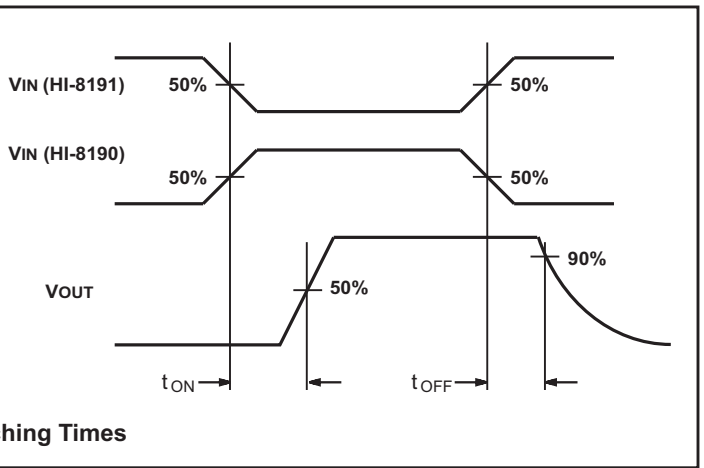
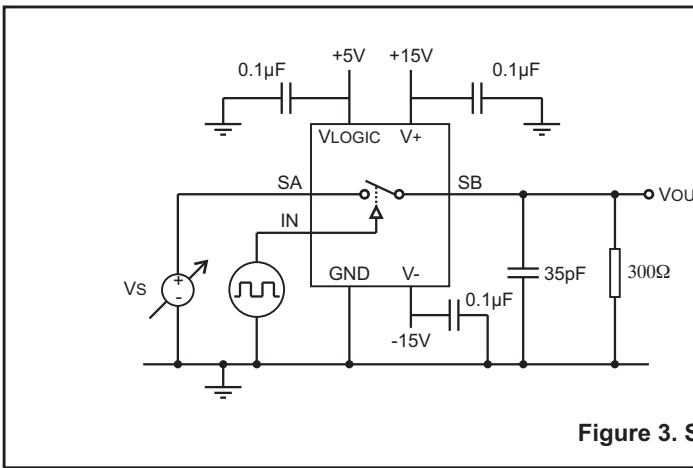
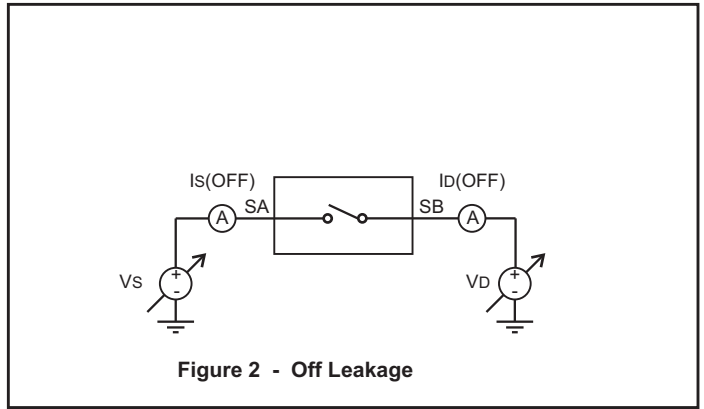
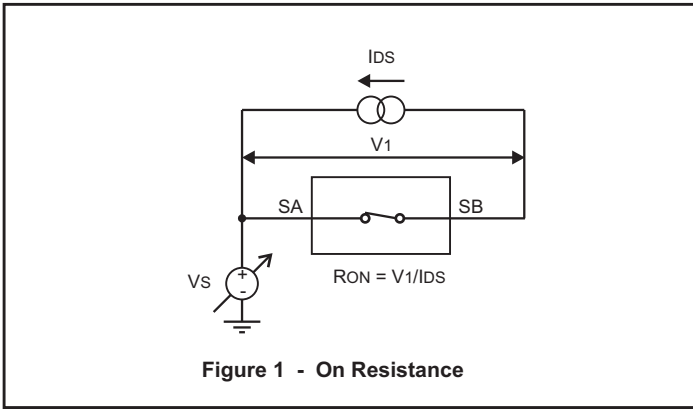

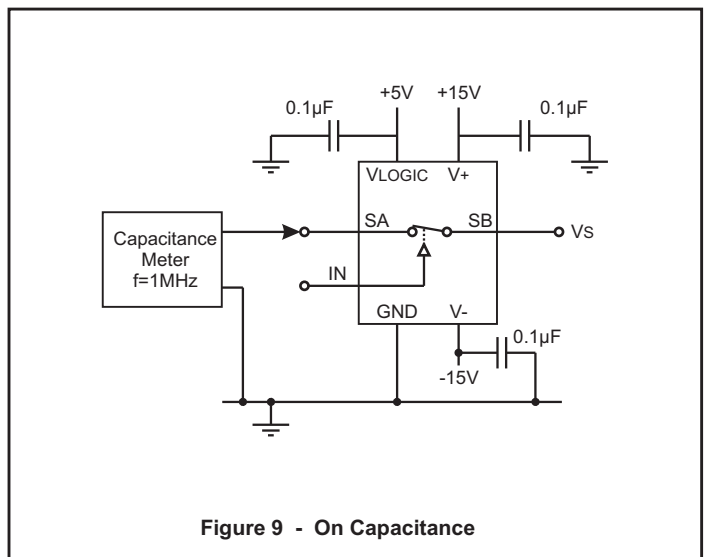
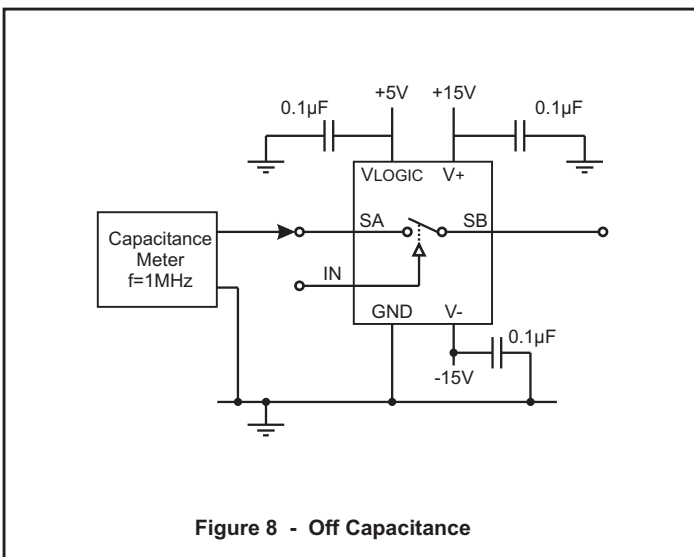
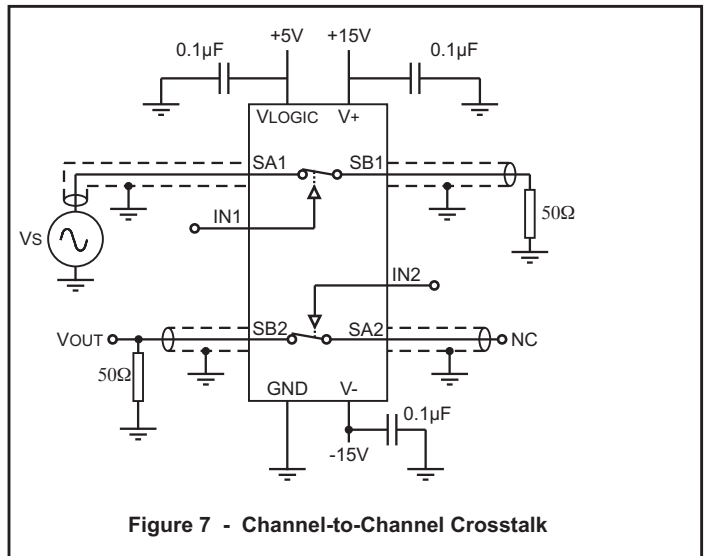
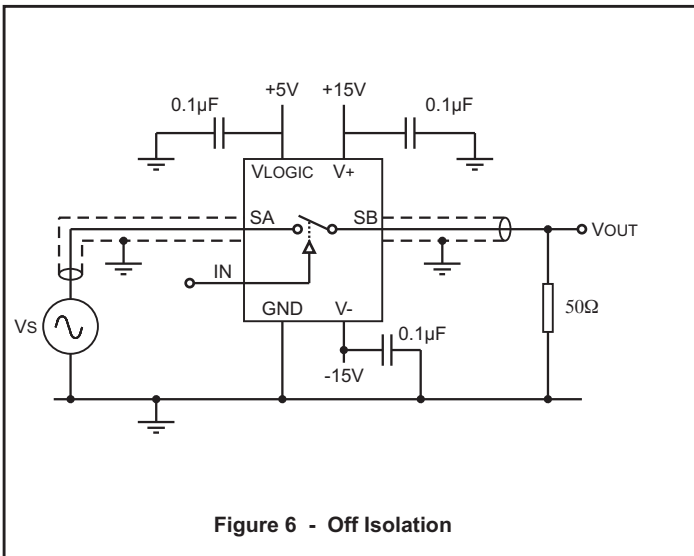
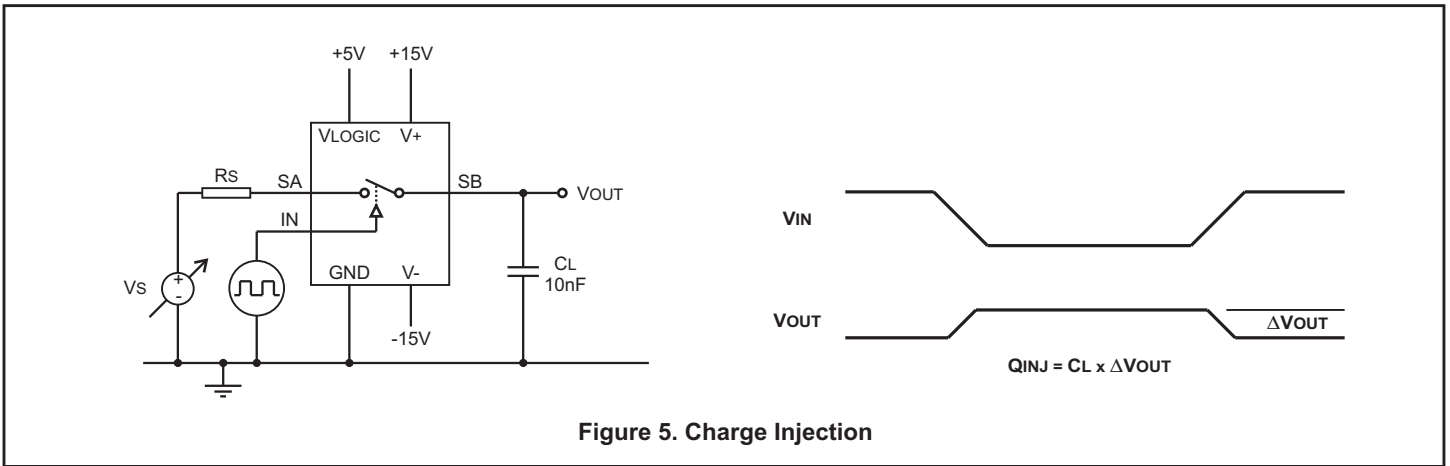

ORDERING INFORMATION

HI - 819x xx x x

PART NUMBER	LEAD FINISH
Blank	Tin / Lead (Sn / Pb) Solder
F	100% Matte Tin (Pb-free, RoHS compliant)

PART NUMBER	TEMPERATURE RANGE	FLOW	BURN IN
I	-40°C TO +85°C	I	NO
T	-55°C TO +125°C	T	NO
M	-55°C TO +125°C	M	YES

PART NUMBER	PACKAGE DESCRIPTION
PC	16 PIN PLASTIC 5x5 mm CHIP SCALE (16PCS1) (No M-flow, Pb-free only)
PS	16 PIN PLASTIC NARROW BODY SOIC (16HN)
PD	16 PIN PLASTIC DIP (16P)

PART NUMBER	FUNCTION
8190	QUAD SWITCH, NORMALLY OPEN
8191	QUAD SWITCH, NORMALLY CLOSED
8192	QUAD SWITCH, TWO NORMALLY OPEN, TWO NORMALLY CLOSED

REVISION HISTORY

P/N	Rev	Date	Description of Change
DS8190	New	10/26/11	Initial release
	A	12/12/11	Update DC and Peak switch current values in maximum ratings. Clarify QFN available only in Pb-free.

16-PIN PLASTIC SMALL OUTLINE (SOIC) - NB
(Narrow Body)

inches (millimeters)
Package Type: 16HN

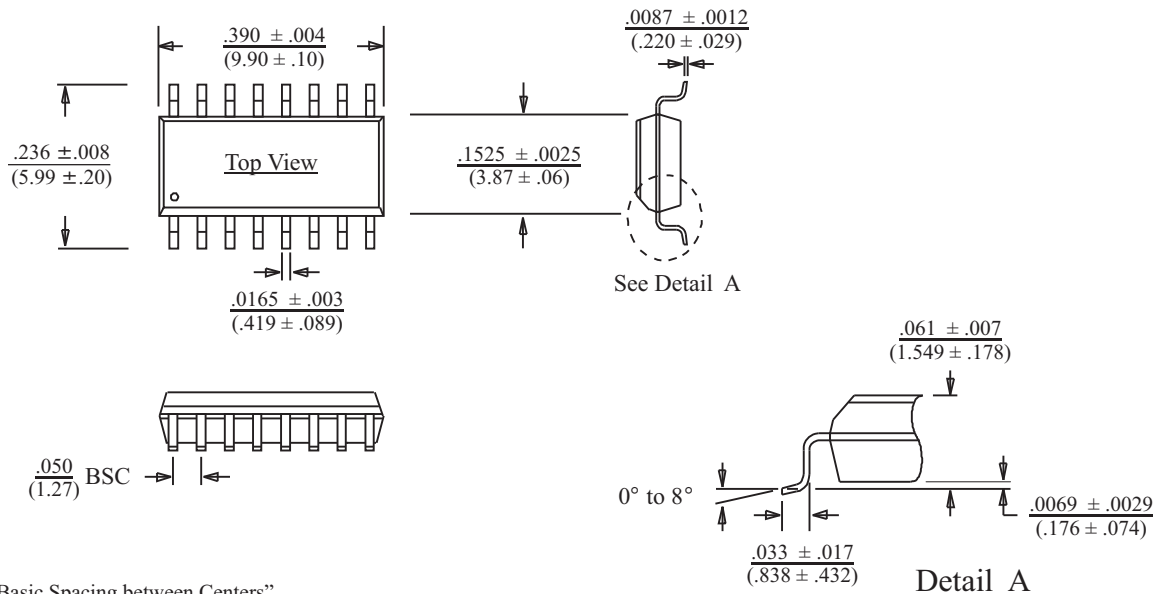

BSC = "Basic Spacing between Centers" is theoretical true position dimension and has no tolerance. (JEDEC Standard 95)

16-PIN PLASTIC CHIP-SCALE PACKAGE

millimeters
Package Type: 16PCS1

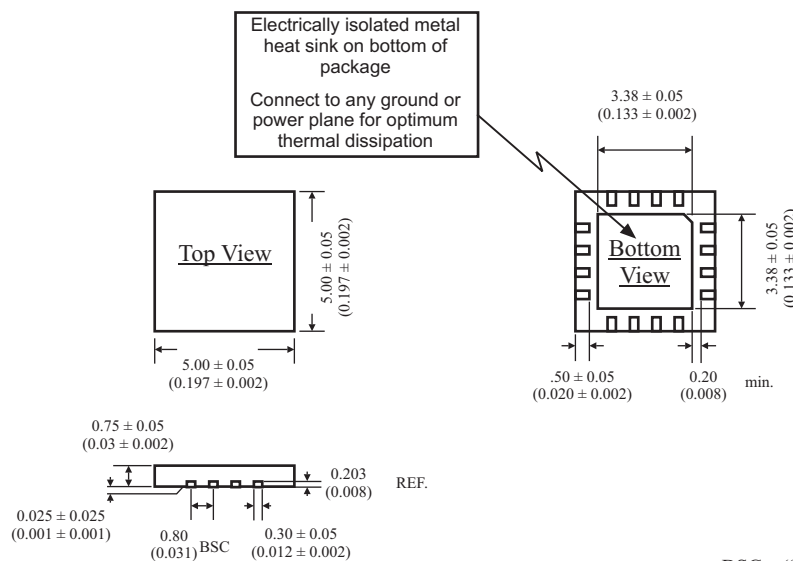

Electrically isolated metal heat sink on bottom of package
Connect to any ground or power plane for optimum thermal dissipation

BSC = "Basic Spacing between Centers" is theoretical true position dimension and has no tolerance. (JEDEC Standard 95)

16-PIN PLASTIC DIP

Package Type: 16P

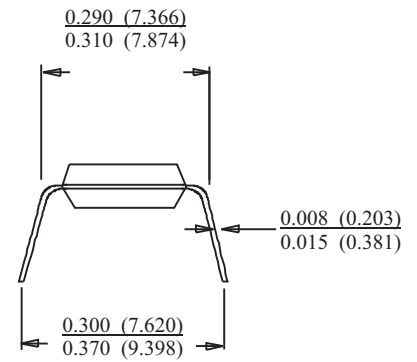
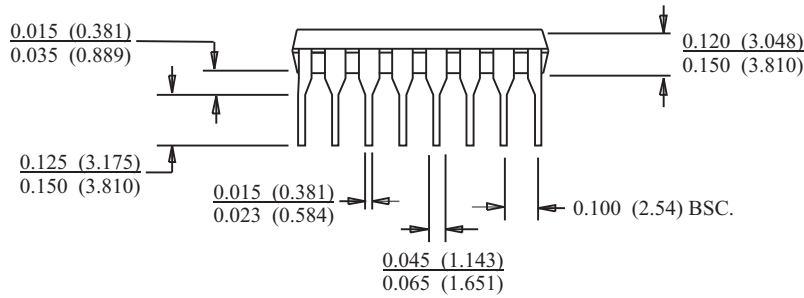
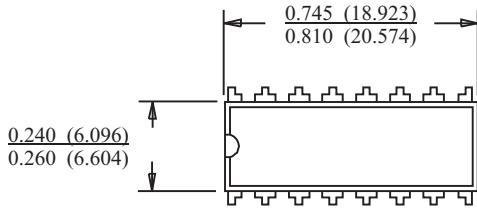

inches (millimeters)