

GENERAL DESCRIPTION

The HI-3584A from Holt Integrated Circuits is a silicon gate CMOS device for interfacing a 16-bit parallel data bus to the ARINC 429 serial bus. The HI-3584A design offers a high-speed host CPU interface compared with the earlier HI-3584 product. The device provides two receivers each with label recognition, a 32 by 32 FIFO, and an analog line receiver. Up to 16 labels may be programmed for each receiver. The independent transmitter also has a 32 by 32 FIFO. The status of all three FIFOs can be monitored using the external status pins or by polling the HI-3584A's status register.

Other features include a programmable option of data or parity in the 32nd bit, and the ability to unscramble the 32 bit word. Also, versions are available with different values of input resistance to allow users to more easily add external lightning protection circuitry.

The 16-bit parallel data bus exchanges the 32-bit ARINC data word in two steps when either loading the transmitter or interrogating the receivers. The databus and all control signals are CMOS and TTL compatible.

The HI-3584A applies the ARINC protocol to the receivers and transmitter. Timing is based on a 1 Megahertz clock.

Additional interface circuitry such as the Holt HI-8570 or HI-8571 is required to translate the transmitter's 3.3 volt logic outputs to ARINC 429 drive levels.

FEATURES

- ARINC specification 429 compatible
- 3.3V logic supply operation
- Dual receiver and transmitter interface
- Analog line receivers connect directly to ARINC bus
- Programmable label recognition
- On-chip 16 label memory for each receiver
- 32 x 32 FIFOs each receiver and transmitter
- Independent data rate selection for transmitter and each receiver
- Status register
- Data scramble control
- 32nd transmit bit can be data or parity
- Self test mode
- Low power
- Industrial & Extended temperature ranges

APPLICATIONS

- Avionics data communication
- Serial to parallel conversion
- Parallel to serial conversion

PIN CONFIGURATIONS (Top View)

(See page 13 for additional pin configuration)

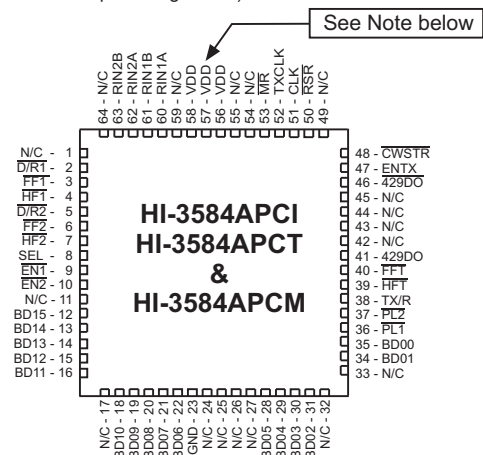

(Note: All 3 VDD pins must be connected to the same 3.3V supply)

64 - Pin Plastic 9mm x 9mm Chip-Scale Package

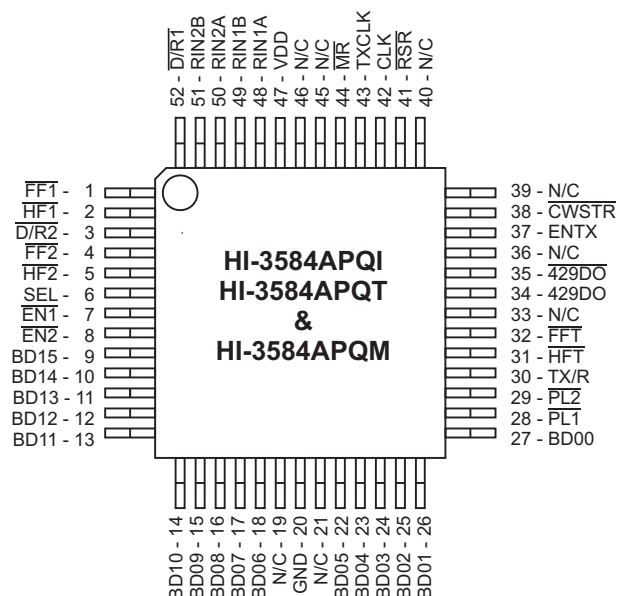

52 - Pin Plastic Quad Flat Pack (PQFP)

PIN DESCRIPTIONS

SIGNAL	FUNCTION	DESCRIPTION
VDD	POWER	+3.3V \pm 5% (All three VDD pins on the chip-scale package <u>must</u> be connect to the same supply)
RIN1A	INPUT	ARINC receiver 1 positive input
RIN1B	INPUT	ARINC receiver 1 negative input
RIN2A	INPUT	ARINC receiver 2 positive input
RIN2B	INPUT	ARINC receiver 2 negative input
$\overline{D/R1}$	OUTPUT	Receiver 1 data ready flag
$\overline{FF1}$	OUTPUT	FIFO full Receiver 1
$\overline{HF1}$	OUTPUT	FIFO Half full, Receiver 1
$\overline{D/R2}$	OUTPUT	Receiver 2 data ready flag
$\overline{FF2}$	OUTPUT	FIFO full Receiver 2
$\overline{HF2}$	OUTPUT	FIFO Half full, Receiver 2
SEL	INPUT	Receiver data byte selection (0 = BYTE 1) (1 = BYTE 2)
$\overline{EN1}$	INPUT	Data Bus control, enables receiver 1 data to outputs
$\overline{EN2}$	INPUT	Data Bus control, enables receiver 2 data to outputs if $\overline{EN1}$ is high
BD15	I/O	Data Bus
BD14	I/O	Data Bus
BD13	I/O	Data Bus
BD12	I/O	Data Bus
BD11	I/O	Data Bus
BD10	I/O	Data Bus
BD09	I/O	Data Bus
BD08	I/O	Data Bus
BD07	I/O	Data Bus
BD06	I/O	Data Bus
GND	POWER	0 V
BD05	I/O	Data Bus
BD04	I/O	Data Bus
BD03	I/O	Data Bus
BD02	I/O	Data Bus
BD01	I/O	Data Bus
BD00	I/O	Data Bus
$\overline{PL1}$	INPUT	Latch enable for byte 1 entered from data bus to transmitter FIFO.
$\overline{PL2}$	INPUT	Latch enable for byte 2 entered from data bus to transmitter FIFO. Must follow $\overline{PL1}$.
TX/R	OUTPUT	Transmitter ready flag. Goes low when ARINC word loaded into FIFO. Goes high after transmission and FIFO empty.
\overline{HFT}	OUTPUT	Transmitter FIFO Half Full
\overline{FFT}	OUTPUT	Transmitter FIFO Full
429DO	OUTPUT	"ONES" data output from transmitter
$\overline{429DO}$	OUTPUT	"ZEROS" data output from transmitter
ENTX	INPUT	Enable Transmission
\overline{CWSTR}	INPUT	Clock for control word register
\overline{RSR}	INPUT	Read Status Register if SEL=0, read Control Register if SEL=1
CLK	INPUT	Master Clock input
TX CLK	OUTPUT	Transmitter Clock equal to Master Clock (CLK), divided by either 10 or 80.
\overline{MR}	INPUT	Master Reset, active low

FUNCTIONAL DESCRIPTION

CONTROL WORD REGISTER

The HI-3584A contains a 16-bit control register which is used to configure the device. The control register bits CR0 - CR15 are loaded from BD00 - BD15 when CWSTR is pulsed low. The control register contents are output on the databus when SEL = 1 and RSR is pulsed low. Each bit of the control register has the following function:

CR Bit	FUNCTION	STATE	DESCRIPTION
CR0	Receiver 1 Data clock Select	0	Data rate = CLK/10
		1	Data rate = CLK/80
CR1	Label Memory Read / Write	0	Normal operation
		1	Load 16 labels using <u>PL1</u> / <u>PL2</u> Read 16 labels using <u>EN1</u> / <u>EN2</u>
CR2	Enable Label Recognition (Receiver 1)	0	Disable label recognition
		1	Enable label recognition
CR3	Enable Label Recognition (Receiver 2)	0	Disable Label Recognition
		1	Enable Label recognition
CR4	Enable 32nd bit as parity	0	Transmitter 32nd bit is data
		1	Transmitter 32nd bit is parity
CR5	Self Test	0	The 429DO and 429D0 digital outputs are internally connected to the receiver logic inputs
		1	Normal operation
CR6	Receiver 1 decoder	0	Receiver 1 decoder disabled
		1	ARINC bits 9 and 10 must match CR7 and CR8
CR7	-	-	If receiver 1 decoder is enabled, the ARINC bit 9 must match this bit
CR8	-	-	If receiver 1 decoder is enabled, the ARINC bit 10 must match this bit
CR9	Receiver 2 Decoder	0	Receiver 2 decoder disabled
		1	ARINC bits 9 and 10 must match CR10 and CR11
CR10	-	-	If receiver 2 decoder is enabled, the ARINC bit 9 must match this bit
CR11	-	-	If receiver 2 decoder is enabled, the ARINC bit 10 must match this bit
CR12	Invert Transmitter parity	0	Transmitter 32nd bit is Odd parity
		1	Transmitter 32nd bit is Even parity
CR13	Transmitter data clock select	0	Data rate=CLK/10, O/P slope=1.5us
		1	Data rate=CLK/80, O/P slope=10us
CR14	Receiver 2 data clock select	0	Data rate=CLK/10
		1	Data rate=CLK/80
CR15	Data format	0	Scramble ARINC data
		1	Unscramble ARINC data

STATUS REGISTER

The HI-3584A contains a 9-bit status register which can be interrogated to determine the status of the ARINC receivers, data FIFOs and transmitter. The contents of the status register are output on BD00 - BD08 when the RSR pin is taken low and SEL = 0. Unused bits are output as zeros. The following table defines the status register bits.

SR Bit	FUNCTION	STATE	DESCRIPTION
SR0	Data ready (Receiver 1)	0	Receiver 1 FIFO empty
		1	Receiver 1 FIFO contains valid data Resets to zero when all data has been read. <u>D/R1</u> pin is the inverse of this bit
SR1	FIFO half full (Receiver 1)	0	Receiver 1 FIFO holds less than 16 words
		1	Receiver 1 FIFO holds at least 16 words. <u>HF1</u> pin is the inverse of this bit.
SR2	FIFO full (Receiver 1)	0	Receiver 1 FIFO not full
		1	Receiver 1 FIFO full. To avoid data loss, the FIFO must be read within one ARINC word period. <u>FF1</u> pin is the inverse of this bit
SR3	Data ready (Receiver 2)	0	Receiver 2 FIFO empty
		1	Receiver 2 FIFO contains valid data Resets to zero when all data has been read. <u>D/R2</u> pin is the inverse of this bit
SR4	FIFO half full (Receiver 2)	0	Receiver 2 FIFO holds less than 16 words
		1	Receiver 2 FIFO holds at least 16 words. <u>HF2</u> pin is the inverse of this bit.
SR5	FIFO full (Receiver 2)	0	Receiver 2 FIFO not full
		1	Receiver 2 FIFO full. To avoid data loss, the FIFO must be read within one ARINC word period. <u>FF2</u> pin is the inverse of this bit
SR6	Transmitter FIFO empty	0	Transmitter FIFO not empty
		1	Transmitter FIFO empty.
SR7	Transmitter FIFO full	0	Transmitter FIFO not full
		1	Transmitter FIFO full. <u>FFT</u> pin is the inverse of this bit.
SR8	Transmitter FIFO half full	0	Transmitter FIFO contains less than 16 words
		1	Transmitter FIFO contains at least 16 words. <u>HFT</u> pin is the inverse of this bit.

FUNCTIONAL DESCRIPTION (cont.)

ARINC 429 DATA FORMAT

Control register bit CR15 is used to control how individual bits in the received or transmitted ARINC word are mapped to the HI-3584A data bus during data read or write operations. The following table describes this mapping:

BYTE 1																
DATA BUS	BD 15	BD 14	BD 13	BD 12	BD 11	BD 10	BD 09	BD 08	BD 07	BD 06	BD 05	BD 04	BD 03	BD 02	BD 01	BD 00
ARINC BIT CR15=0	13	12	11	10	9	31	30	32	1	2	3	4	5	6	7	8
ARINC BIT CR15=1	16	15	14	13	12	11	10	9	8	7	6	5	4	3	2	1
				SDI	SDI			Parity	Label	Label	Label	Label	Label	Label	Label	Label

BYTE 2																
DATA BUS	BD 15	BD 14	BD 13	BD 12	BD 11	BD 10	BD 09	BD 08	BD 07	BD 06	BD 05	BD 04	BD 03	BD 02	BD 01	BD 00
ARINC BIT CR15=0	29	28	27	26	25	24	23	22	21	20	19	18	17	16	15	14
ARINC BIT CR15=1	32	31	30	29	28	27	26	25	24	23	22	21	20	19	18	17
	Parity															

THE RECEIVERS

ARINC BUS INTERFACE

Figure 1 shows the input circuit for each receiver. The ARINC 429 specification requires the following detection levels:

STATE	DIFFERENTIAL VOLTAGE
ONE	+6.5 Volts to +13 Volts
NULL	+2.5 Volts to -2.5 Volts
ZERO	-6.5 Volts to -13 Volts

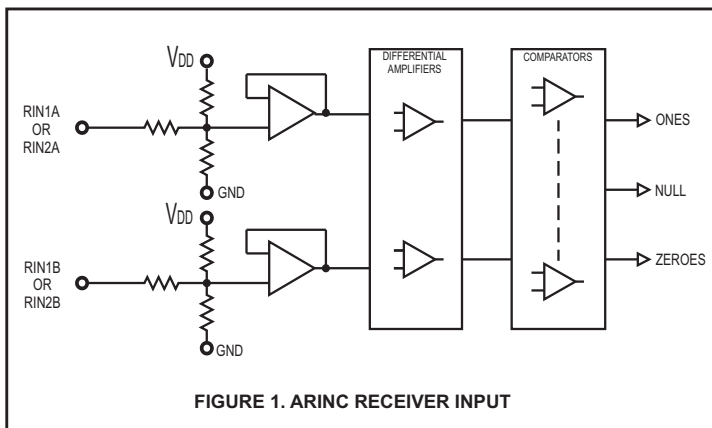

The HI-3584A guarantees recognition of these levels with a common mode Voltage with respect to GND less than $\pm 4V$ for the worst case condition (3.0V supply and 13V signal level).

The tolerances in the design guarantee detection of the above levels, so the actual acceptance ranges are slightly larger. If the ARINC signal is out of the actual acceptance ranges, including the nulls, the chip rejects the data.

RECEIVER LOGIC OPERATION

Figure 2 shows a block diagram of the logic section of each receiver.

BIT TIMING

The ARINC 429 specification contains the following timing specification for the received data:

	HIGH SPEED	LOW SPEED
BIT RATE	100K BPS $\pm 1\%$	12K -14.5K BPS
PULSE RISE TIME	$1.5 \pm 0.5 \mu\text{sec}$	$10 \pm 5 \mu\text{sec}$
PULSE FALL TIME	$1.5 \pm 0.5 \mu\text{sec}$	$10 \pm 5 \mu\text{sec}$
PULSE WIDTH	$5 \mu\text{sec} \pm 5\%$	34.5 to 41.7 μsec

The HI-3584A accepts signals that meet these specifications and rejects signals outside the tolerances. The way the logic operation achieves this is described below:

- Key to the performance of the timing checking logic is an accurate 1MHz clock source. Less than 0.1% error is recommended.
- The sampling shift registers are 10 bits long and must show three consecutive Ones, Zeros or Nulls to be considered valid data. Additionally, for data bits, the One or Zero in the upper bits of the sampling shift registers must be followed by a Null in the lower bits within the data bit time. For a Null in the word gap, three consecutive Nulls must be found in both the upper and lower bits of the sampling shift register. In this manner the minimum pulse width is guaranteed.
- Each data bit must follow its predecessor by not less than 8 samples and no more than 12 samples. In this manner the bit rate is checked. With exactly 1MHz input clock frequency, the acceptable data bit rates are as follows:

	HIGH SPEED	LOW SPEED
DATA BIT RATE MIN	83K BPS	10.4K BPS
DATA BIT RATE MAX	125K BPS	15.6K BPS

- The Word Gap timer samples the Null shift register every 10 input clocks (80 for low speed) after the last data bit of a valid reception. If the Null is present, the Word Gap counter is incremented. A count of 3 will enable the next reception.

FUNCTIONAL DESCRIPTION (cont.)

Once a valid ARINC word is loaded into the FIFO, then EOS clocks the data ready flag flip flop to a "1", $\overline{D/R1}$ or $\overline{D/R2}$ (or both) will go low. The data flag for a receiver will remain low until both ARINC bytes from that receiver are retrieved and the FIFO is empty. This is accomplished by first activating \overline{EN} with SEL, the byte selector, low to retrieve the first byte and then activating \overline{EN} with SEL high to retrieve the second byte. $\overline{EN1}$ retrieves data from receiver 1 and $\overline{EN2}$ retrieves data from receiver 2.

Up to 32 ARINC words may be loaded into each receiver's FIFO. The $\overline{FF1}$ ($\overline{FF2}$) pin will go low when the receiver 1 (2) FIFO is full. Failure to retrieve data from a full FIFO will cause the next valid ARINC word received to overwrite the existing data in FIFO location 32. A FIFO half full flag $\overline{HF1}$ ($\overline{HF2}$) goes low if the FIFO contains 16 or more received ARINC words. The $\overline{HF1}$ ($\overline{HF2}$) pin is intended to act as an interrupt flag to the system's external microprocessor, allowing a 16 word data retrieval routine to be performed, without the user needing to continually poll the HI-3584A's status register bits.

LABEL RECOGNITION

The chip compares the incoming label to the stored labels if label recognition is enabled. If a match is found, the data is processed. If a match is not found, no indicators of receiving ARINC data are presented. Note that 00(Hex) is treated in the same way as any other label value. Label bit significance is not changed by the status of control register bit CR15. Label bits BD00-BD07 are always compared to received ARINC bits 1-8 respectively.

LOADING LABELS

After a write that takes CR1 from 0 to 1, the next 16 writes of data (\overline{PL} pulsed low) load label data into each location of the label memory from the BD00 - BD07 pins. The $\overline{PL1}$ pin is used to write label data for receiver 1 and $\overline{PL2}$ for receiver 2. Note that ARINC word reception is suspended during the label memory write sequence.

READING LABELS

After the write that changes CR1 from 0 to 1, the next 16 data reads of the selected receiver (\overline{EN} taken low) are labels. $\overline{EN1}$ is used to read labels for receiver 1, and $\overline{EN2}$ to read labels for receiver 2. Label data is presented on BD00 - BD07.

When writing to, or reading from the label memory, SEL must be a one, all 16 locations should be accessed, and CR1 must be written to zero before returning to normal operation. Label recognition must be disabled ($CR2/3=0$) during the label read sequence.

TRANSMITTER

FIFO OPERATION

The FIFO is loaded sequentially by first pulsing $\overline{PL1}$ to load byte 1 and then $\overline{PL2}$ to load byte 2. The control logic automatically loads the 31 bit word (or 32 bit word if $CR4=0$) in the next available position of the FIFO. If TX/R, the transmitter ready flag is high (FIFO empty), then up to 32 words, each 31 or 32 bits long, may be loaded. If TX/R is low, then only the available positions may be loaded. If all 32 positions are full, the \overline{FFT} flag is asserted and the FIFO ignores further attempts to load data.

A transmitter FIFO half-full flag \overline{HFT} is provided. When the transmit FIFO contains less than 16 words, \overline{HFT} is high, indicating to the system microprocessor that a 16 ARINC word block write sequence can be initiated.

In normal operation ($CR4=1$), the 32nd bit transmitted is a parity bit. Odd or even parity is selected by programming control register bit CR12 to a zero or one. If CR4 is programmed to a 0, then all 32-bits of data loaded into the transmitter FIFO are treated as data and are transmitted.

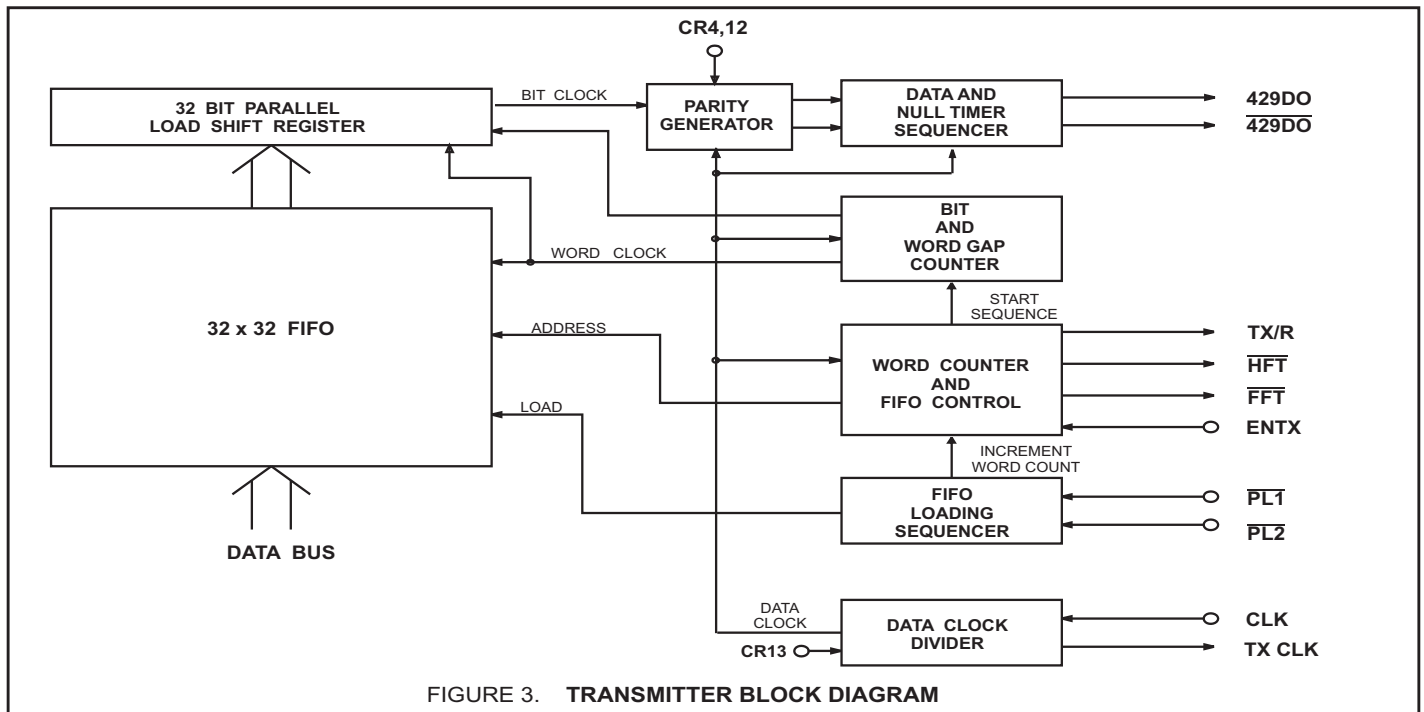

FIGURE 3. TRANSMITTER BLOCK DIAGRAM

FUNCTIONAL DESCRIPTION (cont.)

DATA TRANSMISSION

When ENTX goes high, enabling transmission, the FIFO positions are incremented with the top register loading into the data transmission shift register. Within 2.5 data clocks the first data bit appears at 429DO and 429DO. The 31 or 32 bits in the data transmission shift register are presented sequentially to the outputs in the ARINC 429 format with the following timing:

	<u>HIGH SPEED</u>	<u>LOW SPEED</u>
ARINC DATA BIT TIME	10 Clocks	80 Clocks
DATA BIT TIME	5 Clocks	40 Clocks
NULL BIT TIME	5 Clocks	40 Clocks
WORD GAP TIME	40 Clocks	320 Clocks

The word counter detects when all loaded positions have been transmitted and sets the transmitter ready flag, TX/R, high.

TRANSMITTER PARITY

The parity generator counts the Ones in the 31-bit word. If control register bit CR12 is set low, the 32nd bit transmitted will make parity odd. If the control bit is, high the parity is even. Setting CR4 to a Zero bypasses the parity generator, and allows 32 bits of data to be transmitted.

SELF TEST

If control register bit CR5 is set low, the transmitter serial output data are internally connected to each of the two receivers, bypassing the analog interface circuitry. Data is passed unmodified to receiver 1 and inverted to receiver 2. The serial data from the transmitter is always present on the 429DO and 429DO outputs regardless of the state of CR5.

SYSTEM OPERATION

The two receivers are independent of the transmitter. Therefore, control of data exchanges is strictly at the option of the user. The only restrictions are:

1. The received data will be overwritten if the receiver FIFO is full and at least one location is not retrieved before the next complete ARINC word is received.
2. The transmitter FIFO can store 32 words maximum and ignores attempts to load additional data if full.

REPEATER OPERATION

Repeater mode of operation allows a data word that has been received by the HI-3584A to be placed directly into the transmitter FIFO. Repeater operation is similar to normal receiver operation. In normal operation, either byte of a received data word may be read from the receiver latches first by use of SEL input. During repeater operation however, the lower byte of the data word must be read first. This is necessary because, as the data is being read, it is also being loaded into transmitter FIFO which is always loaded with the lower byte of the data word first. Signal flow for repeater operation is shown in the Timing Diagrams section.

HI-3584A-15

The HI-3584A-15 option is similar to the HI-3584A with the exception that it allows an external 15 Kohm resistor to be added in series with each ARINC input without affecting the ARINC input thresholds. This option is especially useful in applications where lightning protection circuitry is also required.

Each side of the ARINC bus must be connected through a 15 Kohm series resistor in order for the chip to detect the correct ARINC levels. The typical 10 volt differential signal is translated and input to a window comparator and latch. The comparator levels are set so that with the external 15 Kohm resistors, they are just below the standard 6.5 volt minimum ARINC data threshold and just above the standard 2.5 volt maximum ARINC null threshold.

Please refer to the Holt AN-300 Application Note for additional information and recommendations on lightning protection of Holt line drivers and line receivers.

HIGH SPEED OPERATION

The HI-3584A may be operated at clock frequencies beyond that required for ARINC compliant operation. For operation at Master Clock (CLK) frequencies up to 5MHz, please contact Holt applications engineering.

MASTER RESET (MR)

On a Master Reset data transmission and reception are immediately terminated, all three FIFOs are cleared as are the FIFO flags at the device pins and in the Status Register. The Control Register is not affected by a Master Reset.

TIMING DIAGRAMS

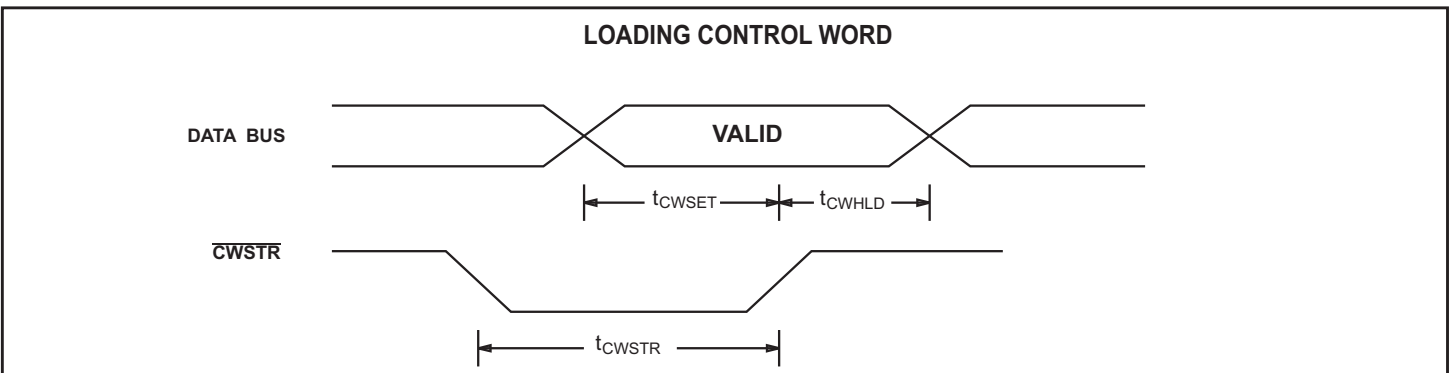
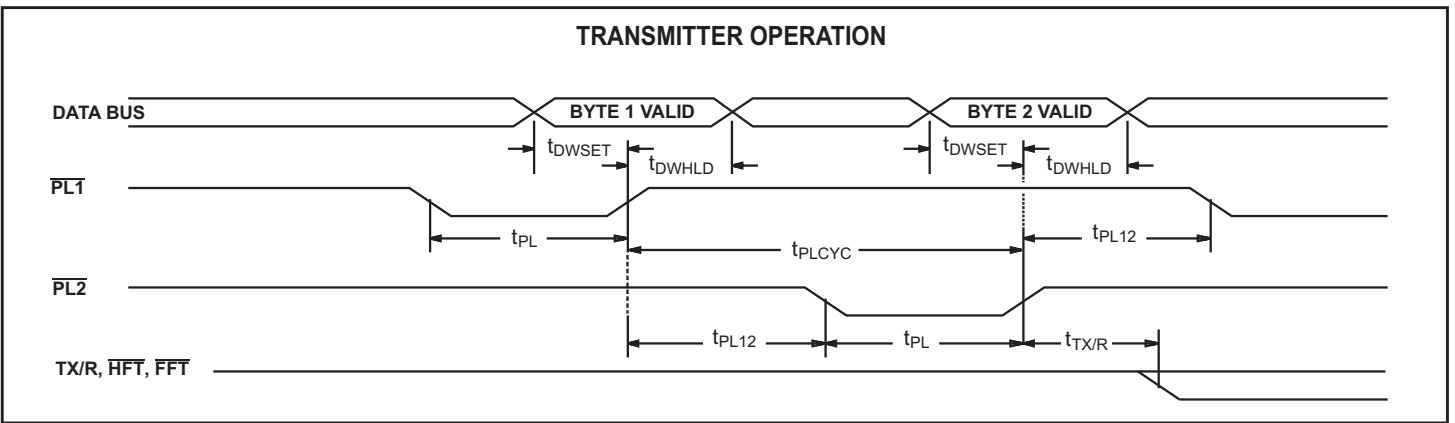
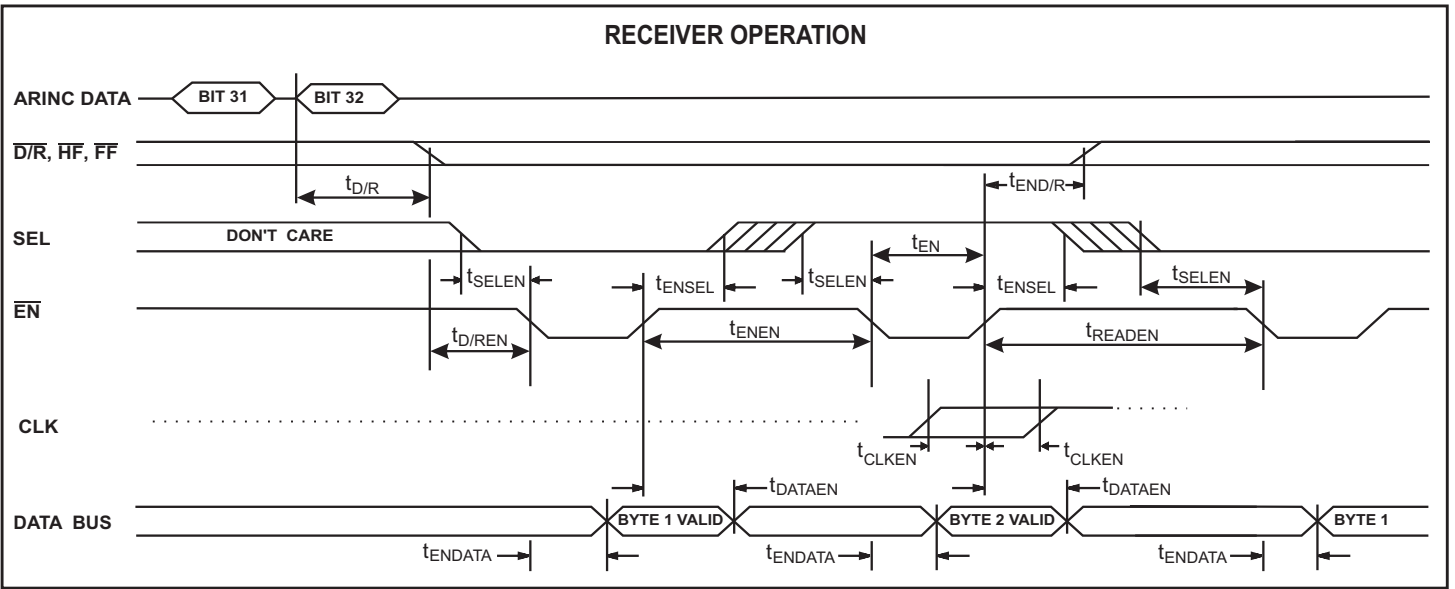
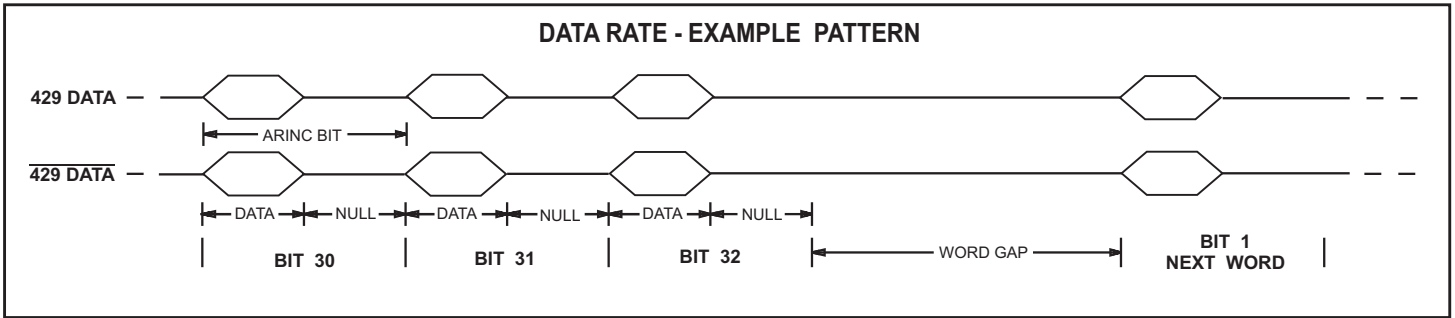

TIMING DIAGRAMS (cont.)

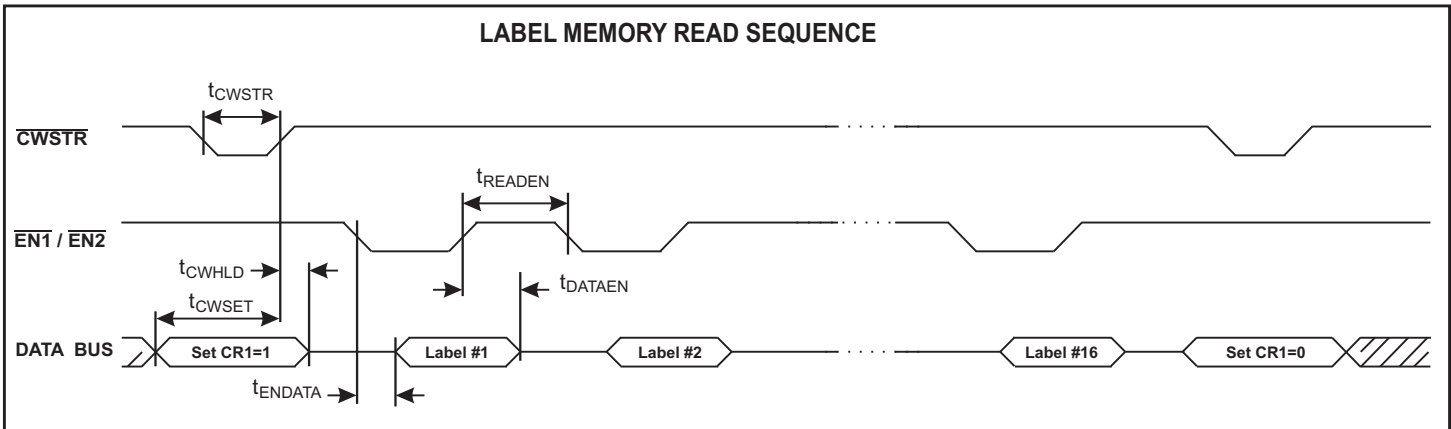
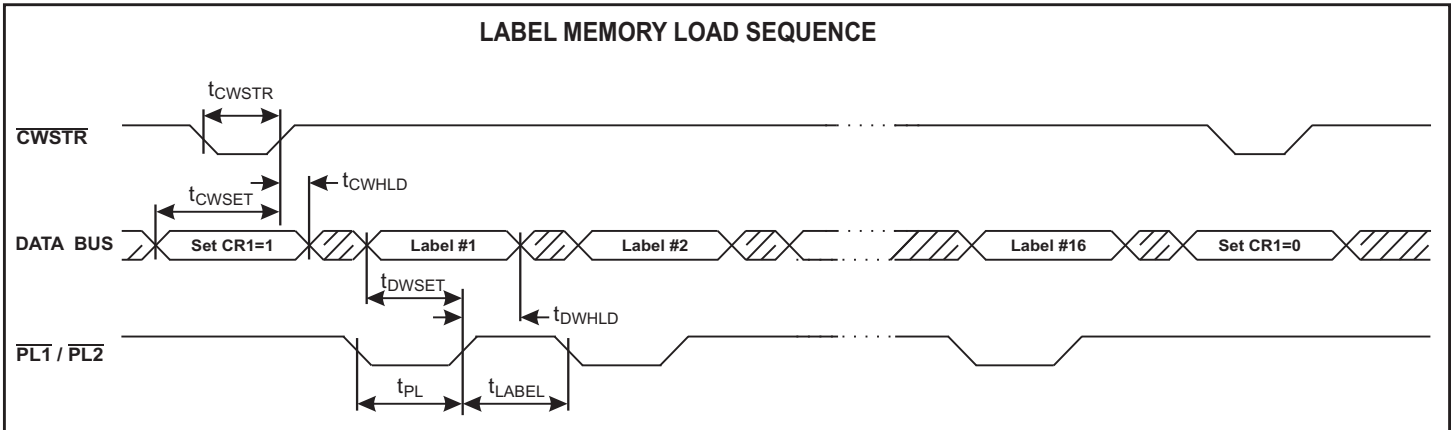
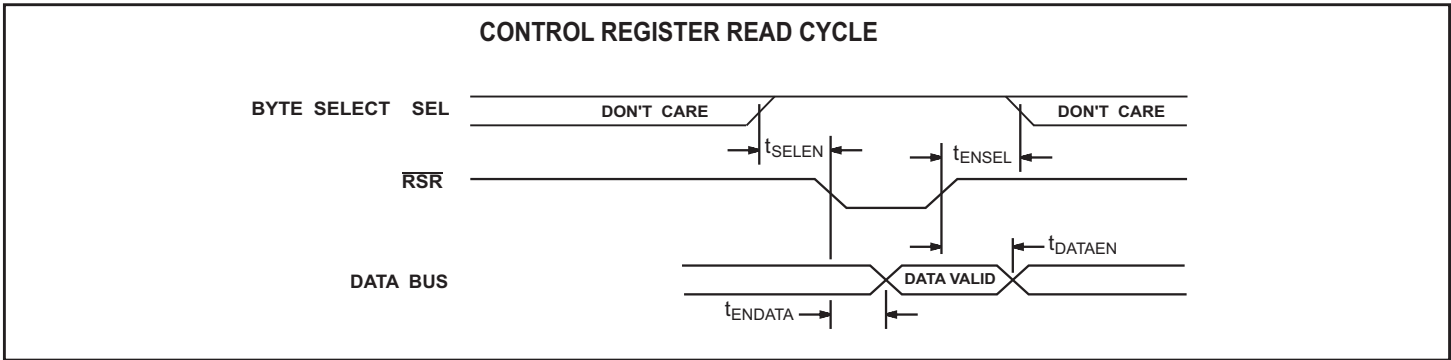
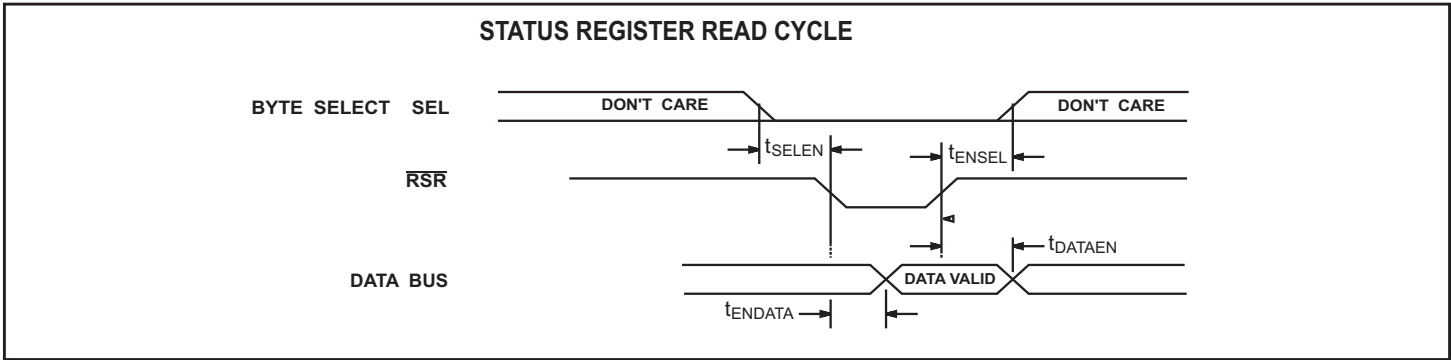

TIMING DIAGRAMS (cont.)

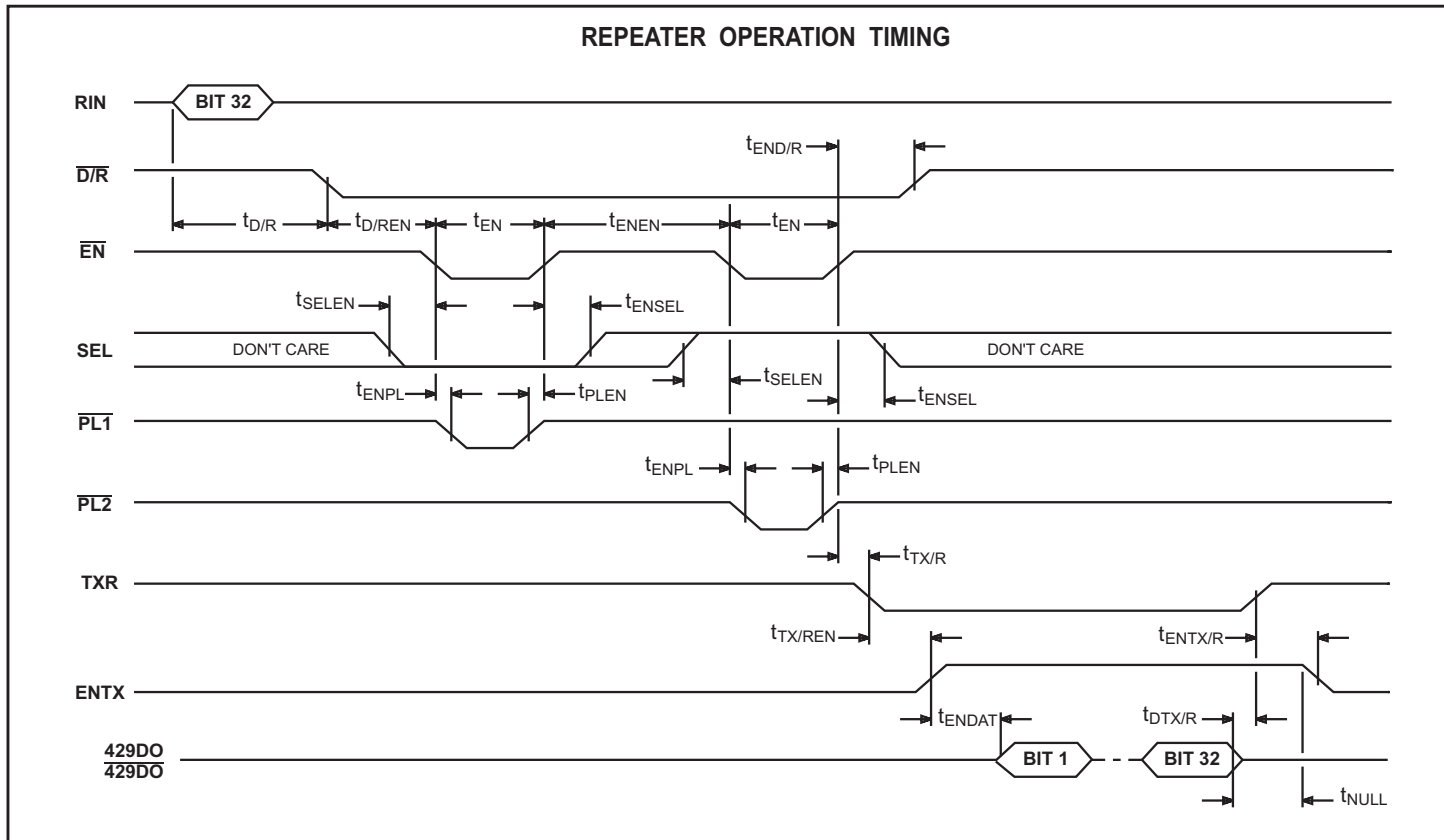
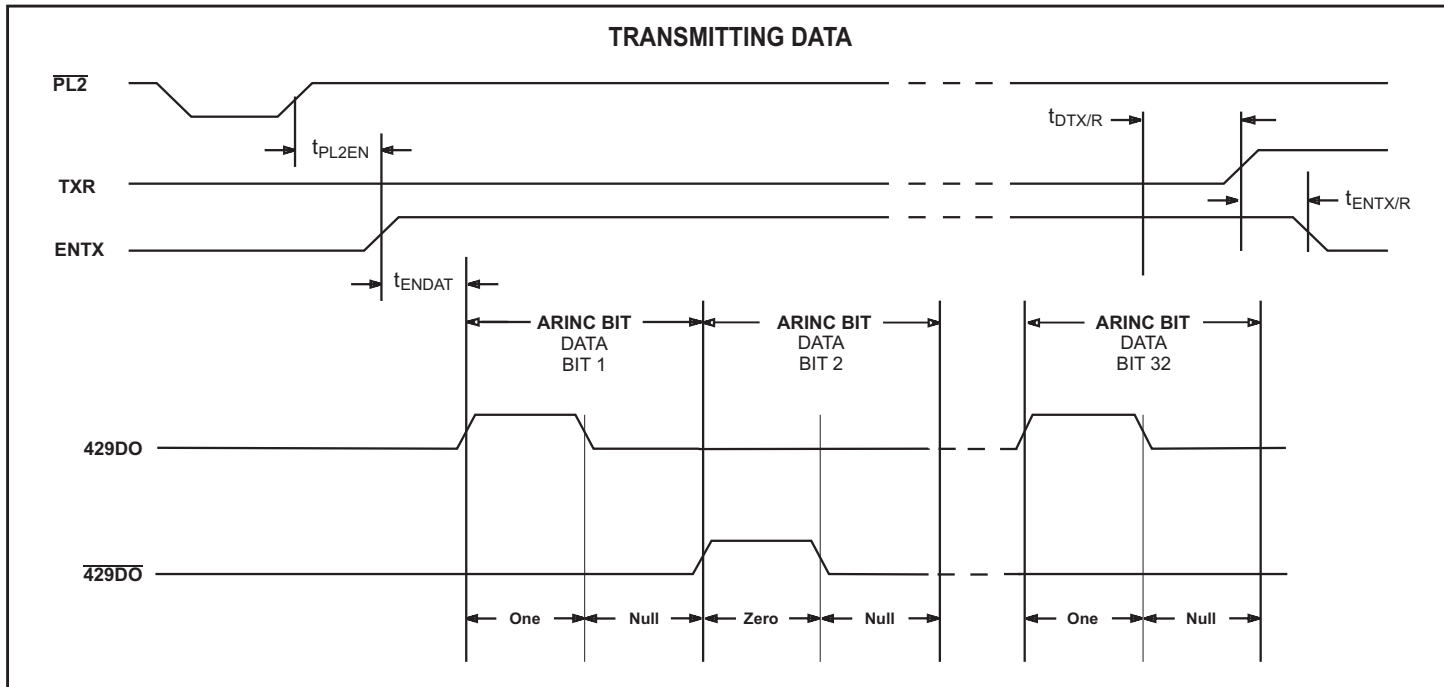

ABSOLUTE MAXIMUM RATINGS

Supply Voltages V _{DD}	-0.3V to +4V	Power Dissipation at 25°C	500 mW
Voltage at pins RIN1A, RIN1B, RIN2A, RIN2B	-29V to +29V	DC Current Drain per pin	±10mA
Voltage at any other pin	-0.3V to V _{DD} +0.3V	Storage Temperature Range	-65°C to +150°C
Solder temperature (Leads)	280°C for 10 seconds	Operating Temperature Range (Industrial):	-40°C to +85°C
(Package)	220°C	(Extended):	-55°C to +125°C

NOTE: Stresses above those listed under "Absolute Maximum Ratings" may cause permanent damage to the device. These are stress ratings only. Functional operation of the device at these or any other conditions above those indicated in the operational sections of the specifications is not implied. Exposure to absolute maximum rating conditions for extended periods may affect device reliability.

DC ELECTRICAL CHARACTERISTICS

V_{DD} = 3.3V, GND = 0V, TA = Operating Temperature Range (unless otherwise specified).

PARAMETER	SYMBOL	CONDITIONS	LIMITS			UNIT
			MIN	TYP	MAX	
ARINC INPUTS - Pins RIN1A, RIN1B, RIN2A, RIN2B						
Differential Input Voltage: (RIN1A to RIN1B, RIN2A to RIN2B)	ONE	V _{IH}	6.5	10.0	13.0	V
	ZERO	V _{IL}	-13.0	-10.0	-6.5	V
	NULL	V _{NUL}	-2.5	0	2.5	V
Input Resistance:	Differential To GND To V _{DD}	R _I	12	80		KΩ
		R _G	12	45		KΩ
		R _H	12	45		KΩ
Input Current:	Input Sink Input Source	I _{IH}			200	μA
		I _{IL}	-450			μA
Input Capacitance: (Guaranteed but not tested)	Differential To GND To V _{DD}	C _I			20	pF
		C _G			20	pF
		C _H			20	pF
BI-DIRECTIONAL INPUTS - Pins BD00 - BD15						
Input Voltage:	Input Voltage HI Input Voltage LO	V _{IH}	70%			V _{DD}
		V _{IL}			30%	V _{DD}
Input Current:	Input Sink Input Source	I _{IH}			1.5	μA
		I _{IL}	-1.5			μA
OTHER INPUTS						
Input Voltage:	Input Voltage HI Input Voltage LO	V _{IH}	70%			V
		V _{IL}			30%	V
Input Current:	Input Sink Input Source Pull-down Current (TEST pin) Pull-up Current (RSR pin)	I _{IH}	-1.5	330	1.5	μA
		I _{IL}				
		I _{PD}				
		I _{PU}				
Input Capacitance: (Guaranteed but not tested)	C _I				15	pF
OUTPUTS						
Output Voltage:	Logic "1" Output Voltage Logic "0" Output Voltage	V _{OH}	I _{OH} = -100μA	V _{DD} - 0.2V		V
		V _{OL}	I _{OL} = 1.0mA		10%V _{DD}	V
Output Current: (All Outputs & Bi-directional Pins)	Output Sink Output Source	I _{OL}	V _{OUT} = 0.4V	1.6		mA
		I _{OH}	V _{OUT} = V _{DD} - 0.4V		-1.0	mA
Output Capacitance:	C _O				15	pF
Operating Supply Current						
V _{DD}	I _{DD}			3.5	7	mA

AC ELECTRICAL CHARACTERISTICS

VDD = 3.3V, GND = 0V, TA = Oper. Temp. Range and fclk=1MHz ±0.1% with 60/40 duty cycle

PARAMETER	SYMBOL	LIMITS			UNITS
		MIN	TYP	MAX	
CONTROL WORD TIMING					
Pulse Width - \overline{CWSTR}	tCWSTR	25			ns
Setup - DATA BUS Valid to \overline{CWSTR} HIGH	tCWSET	25			ns
Hold - \overline{CWSTR} HIGH to DATA BUS Hi-Z	tCWHLDD	5			ns
RECEIVER FIFO AND LABEL READ TIMING					
Delay - Start ARINC 32nd Bit to $\overline{D/R}$ LOW: High Speed	tD/R			16	µs
Low Speed	tD/R			128	µs
Delay - $\overline{D/R}$ LOW to \overline{EN} LOW	tD/REN	0			ns
Delay - \overline{EN} HIGH to $\overline{D/R}$ HIGH	tEND/R			25	ns
Setup - SEL to \overline{EN} LOW	tSELEN	10			ns
Hold - SEL to \overline{EN} HIGH	tENSEL	10			ns
Delay - \overline{EN} LOW to DATA BUS Valid	tENDATA			50	ns
Delay - \overline{EN} HIGH to DATA BUS Hi-Z	tDATAEN			20	ns
Pulse Width - $\overline{EN1}$ or $\overline{EN2}$	tEN	50			ns
Spacing - \overline{EN} HIGH to next \overline{EN} LOW (Same ARINC Word)	tENEN	70			ns
Spacing - \overline{EN} HIGH to next \overline{EN} LOW (Next ARINC Word)	tREADEN	70			ns
CLK HIGH separation from second \overline{EN} pulse HIGH (SEL is HIGH)	tCLKEN	25			ns
TRANSMITTER FIFO AND LABEL WRITE TIMING					
Pulse Width - $\overline{PL1}$ or $\overline{PL2}$	tPL	30			ns
Setup - DATA BUS Valid to \overline{PL} HIGH	tDWSET	30			ns
Hold - \overline{PL} HIGH to DATA BUS Hi-Z	tDWHLD	10			ns
Spacing - $\overline{PL1}$ or $\overline{PL2}$	tPL12	40		tCLK-10	ns
Spacing - $\overline{PL1}$ rising to $\overline{PL2}$ rising	tPLCYC				ns
Spacing between Label Write pulses	tLABEL	40			ns
Delay - $\overline{PL2}$ HIGH to TX/R LOW	tTX/R			30	ns
TRANSMISSION TIMING					
Spacing - $\overline{PL2}$ HIGH to ENTX HIGH	tPL2EN	0			µs
Delay - 32nd ARINC Bit to TX/R HIGH	tDTX/R			50	ns
Spacing - TX/R HIGH to ENTX LOW	tENTX/R	0			ns
Delay - ENTX HIGH to 429DO or 429D \overline{O} : High Speed	tENDAT			25	µs
Delay - ENTX HIGH to 429DO or 429D \overline{O} : Low Speed	tENDAT			200	µs
REPEATER OPERATION TIMING					
Delay - \overline{EN} LOW to \overline{PL} LOW	tENPL	0			ns
Hold - \overline{PL} HIGH to \overline{EN} HIGH	tPLEN	0			ns
Delay - TX/R LOW to ENTX HIGH	tTX/REN	0			ns
MASTER RESET PULSE WIDTH					
	tMR	175			ns
ARINC DATA RATE AND BIT TIMING					
				± 1%	

HEAT SINK - CHIP-SCALE PACKAGE ONLY

The HI-3584APCI and HI-3584APCT use a 64-pin plastic chip-scale package. This package has a metal heat sink pad on its bottom surface. This heat sink is electrically connected to the die. To enhance thermal dissipation, the

heat sink can be soldered to matching circuit board pad. The heat sink may be connected to GND or left floating.

Do not connect heat sink pad to VDD.

ADDITIONAL HI-3584A PIN CONFIGURATION

(See page 1 for additional pin configurations)

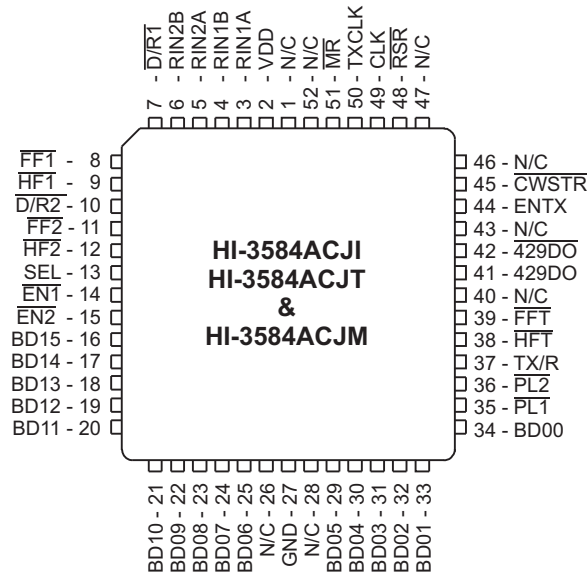

52 - Pin Cerquad J-lead

ORDERING INFORMATION

HI - 3584A xx x x - xx

PART NUMBER	INPUT SERIES RESISTANCE	
	BUILT-IN	REQUIRED EXTERNALLY
No dash number	35K Ohm	0
-15	20K Ohm	15K Ohm

PART NUMBER	PACKAGE DESCRIPTION
Blank	Tin / Lead (Sn / Pb) Solder
F	100% Matte Tin (Pb-free RoHS compliant)

PART NUMBER	TEMPERATURE RANGE	FLOW	BURN IN
I	-40°C TO +85°C	I	No
T	-55°C TO +125°C	T	No
M	-55°C TO +125°C	M	Yes

PART NUMBER	PACKAGE DESCRIPTION
CJ	52 PIN J-LEAD CERQUAD (52U) not available Pb-free
PC	64 PIN PLASTIC CHIP-SCALE LPCC (64PCS)
PQ	52 PIN PLASTIC QUAD FLAT PACK PQFP (52PTQS)

REVISION HISTORY

P/N	Rev	Date	Description of Change
DS3584A	NEW	04/28/09	Initial Release
	A	04/27/10	Added CLKEN to timing parameters.
	B	06/29/10	Added PLCYC to timing parameters.

52-PIN J-LEAD CERQUAD

inches (millimeters)

Package Type: 52U

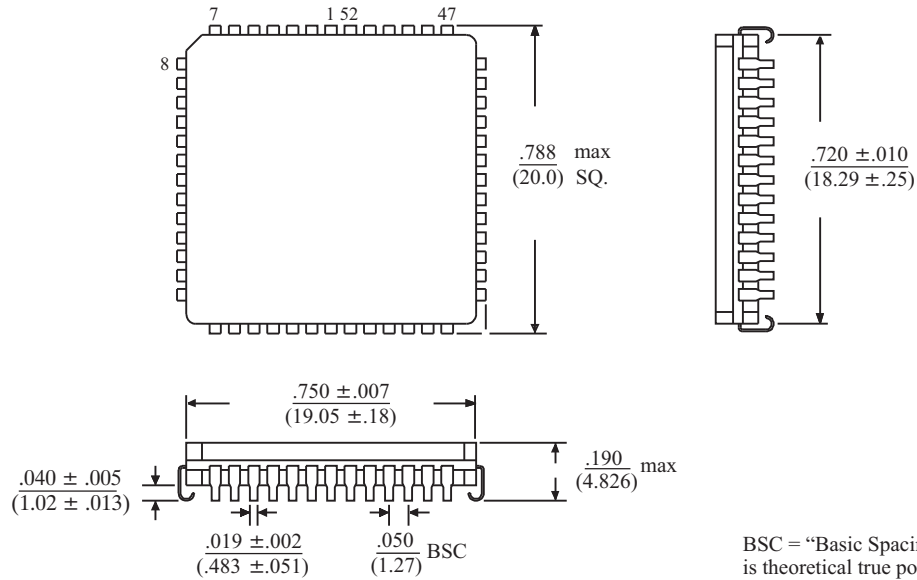

BSC = "Basic Spacing between Centers" is theoretical true position dimension and has no tolerance. (JEDEC Standard 95)

52-PIN PLASTIC QUAD FLAT PACK (PQFP)

inches (millimeters)

Package Type: 52PTQS

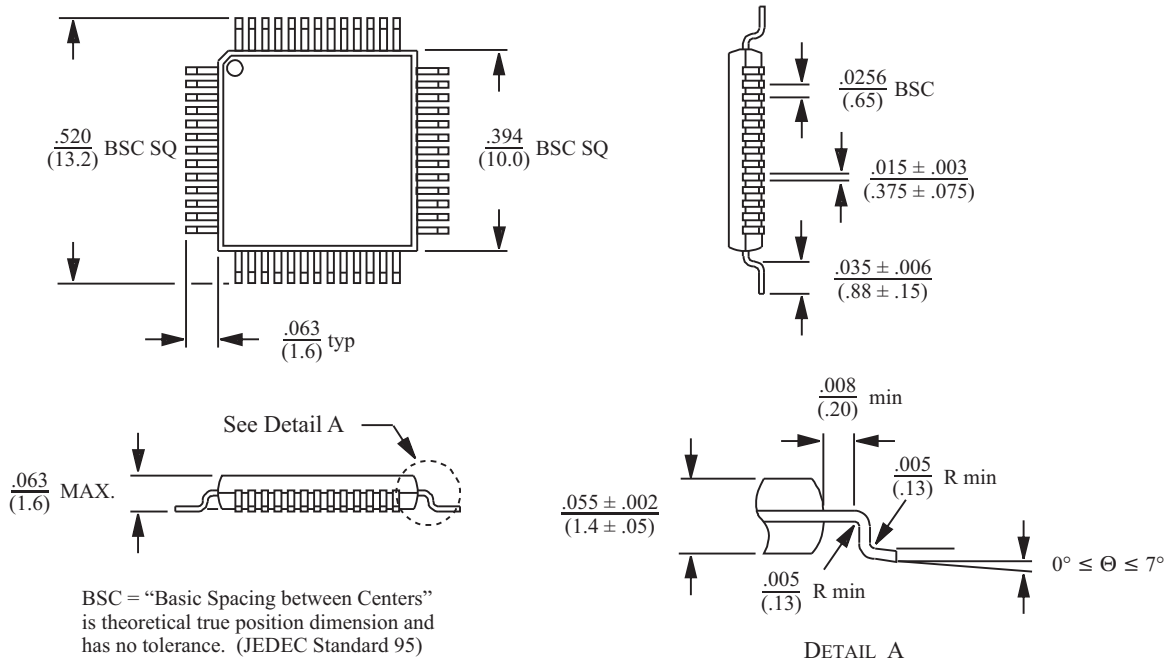

BSC = "Basic Spacing between Centers" is theoretical true position dimension and has no tolerance. (JEDEC Standard 95)

DETAIL A

64-PIN PLASTIC CHIP-SCALE PACKAGE

inches (millimeters)

Package Type: 64PCS

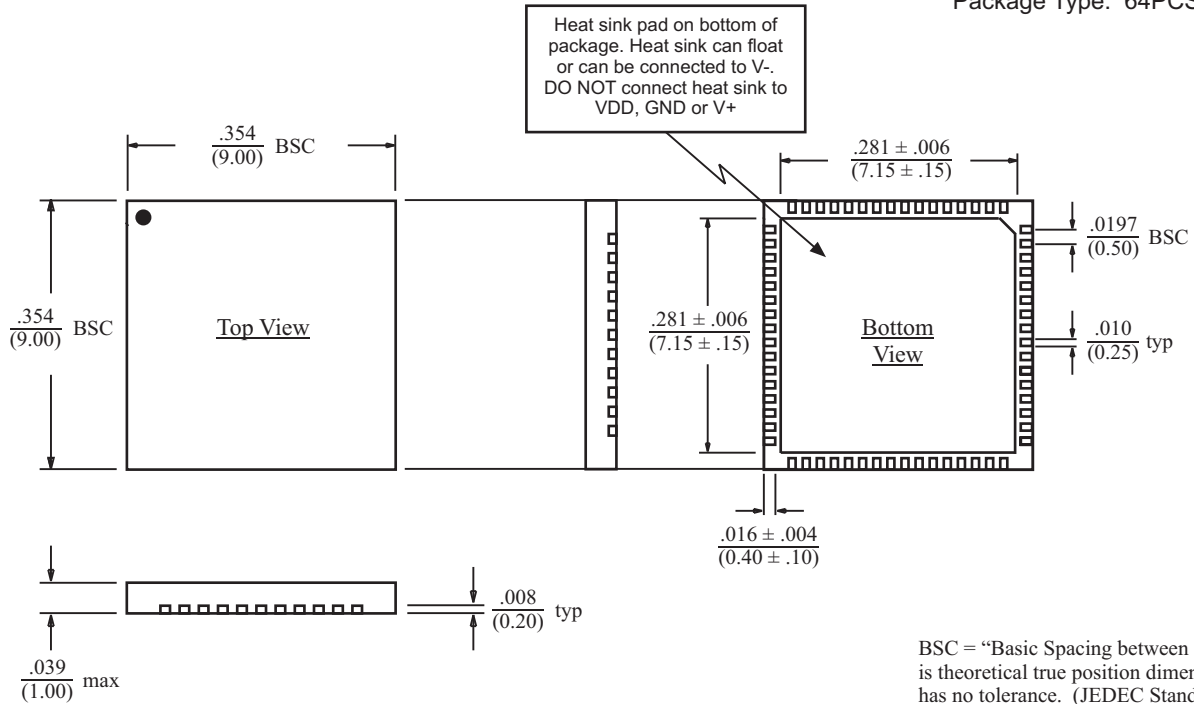

BSC = "Basic Spacing between Centers" is theoretical true position dimension and has no tolerance. (JEDEC Standard 95)