



## PIN DESCRIPTIONS

PIN (DIP & SOIC)	SYMBOL	FUNCTION	DESCRIPTION
1	VDDA	power supply	+3.3 volt power for transceiver A
2	BUSA	analog output	MIL-STD-1533 bus driver A, positive signal
3	$\overline{BUSA}$	analog output	MIL-STD-1553 bus driver A, negative signal
4	RXENA	digital input	Receiver A enable. If low, forces RXA and $\overline{RXA}$ low
5	GNDA	power supply	Ground for transceiver A
6	Vddb	power supply	+3.3 volt power for transceiver B
7	BUSB	analog output	MIL-STD-1533 bus driver B, positive signal
8	$\overline{BUSB}$	analog output	MIL-STD-1553 bus driver B, negative signal
9	RXENB	digital input	Receiver B enable. If low, forces RXB and $\overline{RXB}$ low
10	GNDB	power supply	Ground for transceiver B
11	$\overline{RXB}$	digital output	Receiver B output, inverted
12	RXB	digital output	Receiver B output, non-inverted
13	TXINHB	digital input	Transmit inhibit, bus B. If high BUSB, $\overline{BUSB}$ disabled
14	TXB	digital input	Transmitter B digital data input, non-inverted
15	$\overline{TXB}$	digital input	Transmitter B digital data input, inverted
16	$\overline{RXA}$	digital output	Receiver A output, inverted
17	RXA	digital output	Receiver A output, non-inverted
18	TXINHA	digital input	Transmit inhibit, bus A. If high BUSA, $\overline{BUSA}$ disabled
19	TXA	digital input	Transmitter A digital data input, non-inverted
20	$\overline{TXA}$	digital input	Transmitter A digital data input, inverted

## FUNCTIONAL DESCRIPTION

The HI-1579 family of dual data bus transceivers contains differential voltage source drivers and differential receivers. It is intended for applications using a MIL-STD-1553 A/B data bus. The device produces a trapezoidal output waveform during transmission.

### TRANSMITTER

Data input to the device's transmitter section is from the complementary CMOS inputs TXA/B and  $\overline{TXA/B}$ . The transmitter accepts Manchester II bi-phase data and converts it to differential voltages on BUSA/B and  $\overline{BUSA/B}$ . The transceiver outputs are either direct or transformer coupled to the MIL-STD-1553 data bus. Both coupling methods produce a nominal voltage on the bus of 7.5 volts peak to peak.

The transmitter is automatically inhibited and placed in the high impedance state when both TXA/B and  $\overline{TXA/B}$  are either at a logic "1" or logic "0" simultaneously. A logic "1" applied to the TXINHA/B input will force the transmitter to the high impedance state, regardless of the state of TXA/B and  $\overline{TXA/B}$ .

### RECEIVER

The receiver accepts bi-phase differential data from the MIL-STD-1553 bus through the same direct or transformer coupled interface as the transmitter. The receiver's differential input stage drives a filter and threshold comparator that produces CMOS data at the RXA/B and  $\overline{RXA/B}$  output pins. When the MIL-STD-1553 bus is idle and RXENA or RXENB are high, RXA/B will be logic "0" on HI-1579 and logic "1" on HI-1581.

Each set of receiver outputs can also be independently forced to the bus idle state (logic "0" on HI-1579 or logic "1" on HI-1581) by setting RXENA or RXENB low.

### MIL-STD-1553 BUS INTERFACE

A direct coupled interface (see Figure 2) uses a 1:2.5 ratio isolation transformer and two 55 ohm isolation resistors between the transformer and the bus.

In a transformer coupled interface (see Figure 3), the transceiver is also connected to a 1:2.5 isolation transformer which in turn is connected to a 1:1.4 coupling transformer. The transformer coupled method also requires two coupling resistors equal to 75% of the bus characteristic impedance ( $Z_0$ ) between the coupling transformer and the bus.

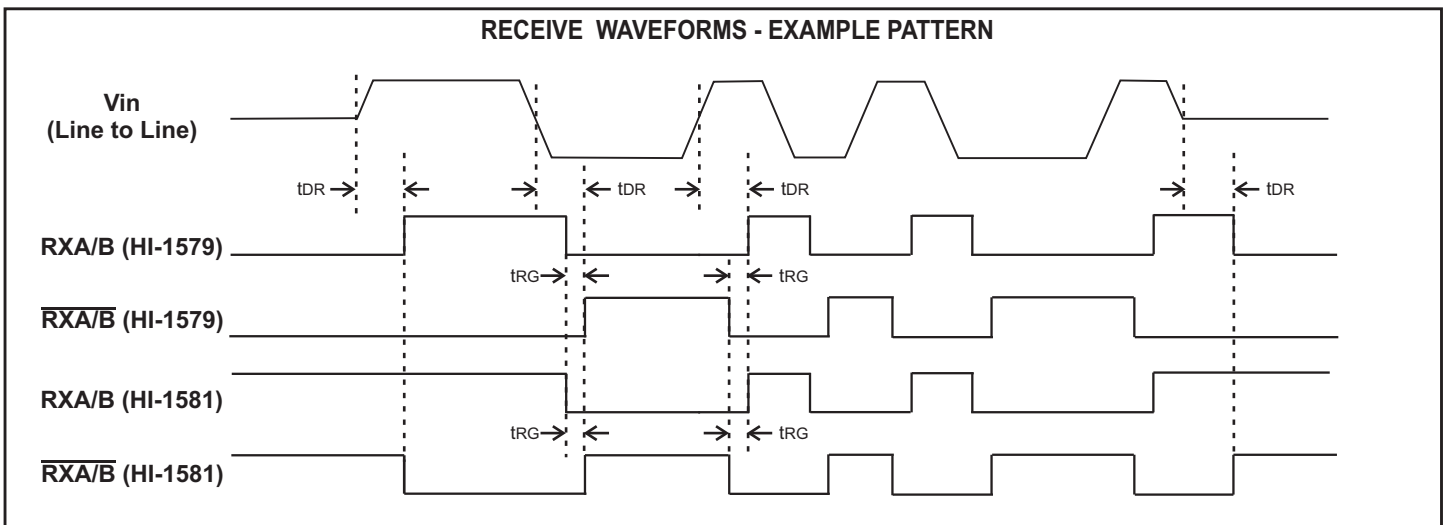
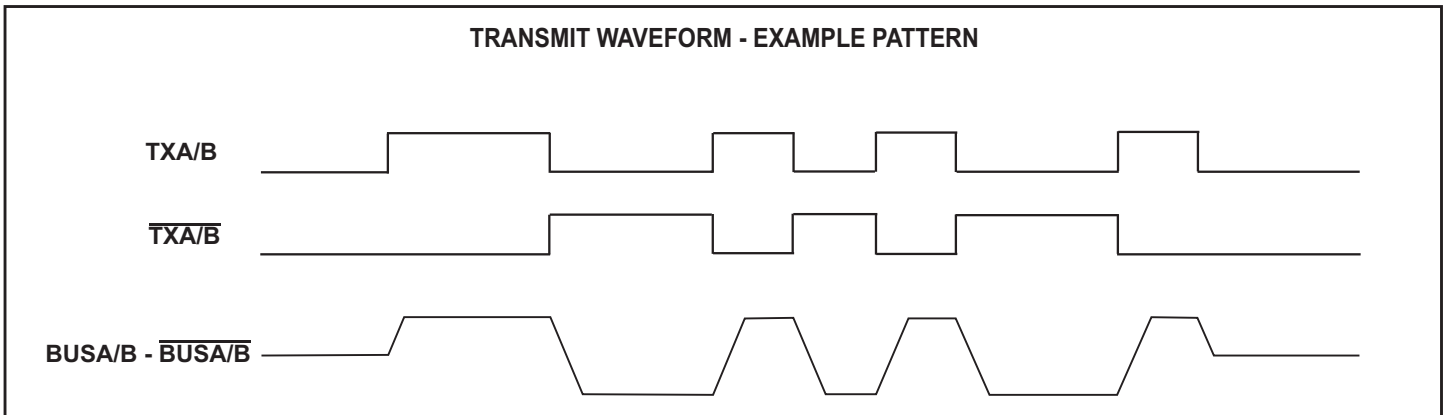
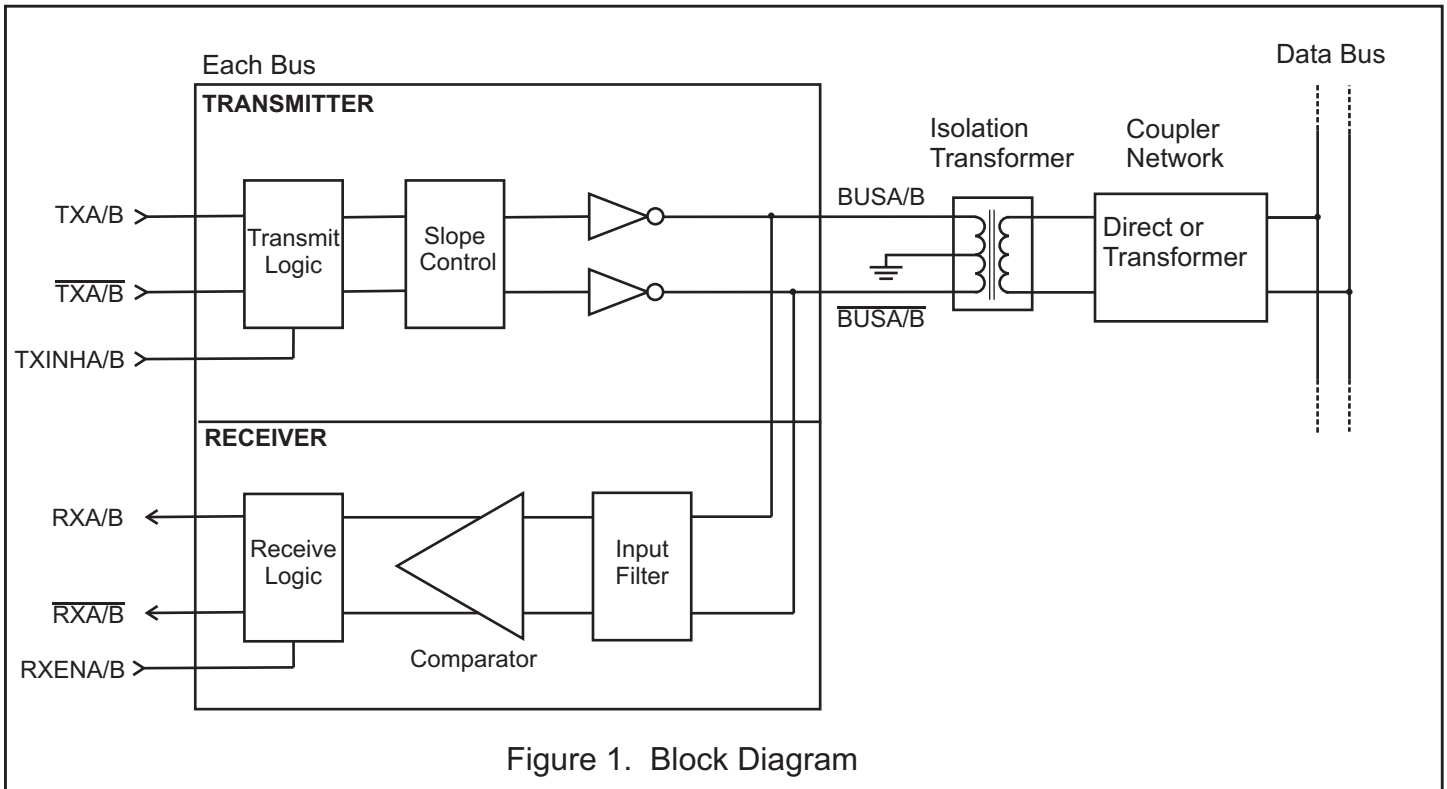

**ABSOLUTE MAXIMUM RATINGS**

Supply voltage (VDD)	-0.3 V to +5 V
Logic input voltage range	-0.3 V dc to +3.6 V
Receiver differential voltage	10 Vp-p
Driver peak output current	+1.0 A
Power dissipation at 25°C ceramic DIL, derate	1.0 W 7mW/°C
Solder Temperature	275°C for 10 sec.
Junction Temperature	175°C
Storage Temperature	-65°C to +150°C

**RECOMMENDED OPERATING CONDITIONS**

Supply Voltage	VDD..... 3.3V... ±5%
Temperature Range	Industrial ..... -40°C to +85°C Hi-Temp ..... -55°C to +125°C

*NOTE: Stresses above absolute maximum ratings or outside recommended operating conditions may cause permanent damage to the device. These are stress ratings only. Operation at the limits is not recommended.*

**DC ELECTRICAL CHARACTERISTICS**

VDD = 3.3 V, GND = 0V, TA = Operating Temperature Range (unless otherwise specified).

PARAMETER	SYMBOL	CONDITION	MIN	TYP	MAX	UNITS
Operating Voltage	VDD		3.15	3.30	3.45	V
Total Supply Current	ICC1	Not Transmitting		4	10	mA
	ICC2	Transmit one bus @ 50% duty cycle		225	320	mA
	ICC3	Transmit one bus @ 100% duty cycle		425	640	mA
Power Dissipation	PD1	Not Transmitting			0.06	W
	PD2	Transmit one bus @ 100% duty cycle			1.0	W
Min. Input Voltage (HI)	V <sub>IH</sub>	Digital inputs	70%			VDD
Max. Input Voltage (LO)	V <sub>IL</sub>	Digital inputs			30%	VDD
Min. Input Current (HI)	I <sub>IH</sub>	Digital inputs			20	µA
Max. Input Current (LO)	I <sub>IL</sub>	Digital inputs	-20			µA
Min. Output Voltage (HI)	V <sub>OH</sub>	I <sub>OUT</sub> = -1.0mA, Digital outputs	90%			VDD
Max. Output Voltage (LO)	V <sub>OL</sub>	I <sub>OUT</sub> = 1.0mA, Digital outputs			10%	VDD
<b>RECEIVER (Measured at Point "Ad" in Figure 2 unless otherwise specified)</b>						
Input resistance	R <sub>IN</sub>	Differential (at chip BUS pins)	20			Kohm
Input capacitance	C <sub>IN</sub>	Differential			5	pF
Common mode rejection ratio	CMRR		40			dB
Input Level	V <sub>IN</sub>	Differential			9	Vp-p
Input common mode voltage	V <sub>ICM</sub>		-5.0		5.0	V-pk
Threshold Voltage - Direct-coupled	Detect	1 MHz Sine Wave (Measured at Point "Ad" in Figure 2)  (RX pulse width 70 ns)	V <sub>THD</sub>	0.65	20.0	Vp-p
	No Detect		V <sub>THND</sub>		0.45	Vp-p
Threshold Voltage - Transformer-coupled	Detect	1 MHz Sine Wave (Measured at Point "At" in Figure 3)  (RX pulse width 70 ns)	V <sub>THD</sub>	0.65	14.0	Vp-p
	No Detect		V <sub>THND</sub>		0.45	Vp-p

## DC ELECTRICAL CHARACTERISTICS (cont.)

VDD = 3.3 V, GND = 0V, TA = Operating Temperature Range (unless otherwise specified).

PARAMETER	SYMBOL	CONDITION	MIN	TYP	MAX	UNITS	
<b>TRANSMITTER (Measured at Point "Ad" in Figure 2 unless otherwise specified)</b>							
Output Voltage	Direct coupled	V <sub>OUT</sub>	35 ohm load (Measured at Point "Ad" in Figure 2)	6.1		9.0	Vp-p
	Transformer coupled	V <sub>OUT</sub>	70 ohm load (Measured at Point "At" in Figure 3)	20.0		27.0	Vp-p
Output Noise		V <sub>ON</sub>	Differential, inhibited			10.0	mVp-p
Output Dynamic Offset Voltage	Direct coupled	V <sub>DYN</sub>	35 ohm load (Measured at Point "Ad" in Figure 2)	-90		90	mV
	Transformer coupled	V <sub>DYN</sub>	70 ohm load (Measured at Point "At" in Figure 3)	-250		250	mV
Output resistance		R <sub>OUT</sub>	Differential, not transmitting	10			Kohm
Output Capacitance		C <sub>OUT</sub>	1 MHz sine wave			15	pF

## AC ELECTRICAL CHARACTERISTICS

VDD = 3.3 V, GND = 0V, TA = Operating Temperature Range (unless otherwise specified).

PARAMETER	SYMBOL	TEST CONDITIONS	MIN	TYP	MAX	UNITS
<b>RECEIVER (Measured at Point "Ad" in Figure 2)</b>						
Receiver Delay	t <sub>DR</sub>	From input zero crossing to RXA/B or $\overline{RXA/B}$			450	ns
Receiver gap time	t <sub>RG</sub>	Spacing between RXA/B and $\overline{RXA/B}$ pulses	90		365	ns
Receiver Enable Delay	t <sub>REN</sub>	From RXENA/B rising or falling edge to RXA/B or $\overline{RXA/B}$			40	ns
<b>TRANSMITTER (Measured at Point "Ad" in Figure 2)</b>						
Driver Delay	t <sub>DT</sub>	TXA/B, TXA/B to BUSA/B, BUSA/B			150	ns
Rise time	t <sub>r</sub>	35 ohm load	100		300	ns
Fall Time	t <sub>f</sub>	35 ohm load	100		300	ns
Inhibit Delay	t <sub>DI-H</sub>	Inhibited output			100	ns
	t <sub>DI-L</sub>	Active output			150	ns

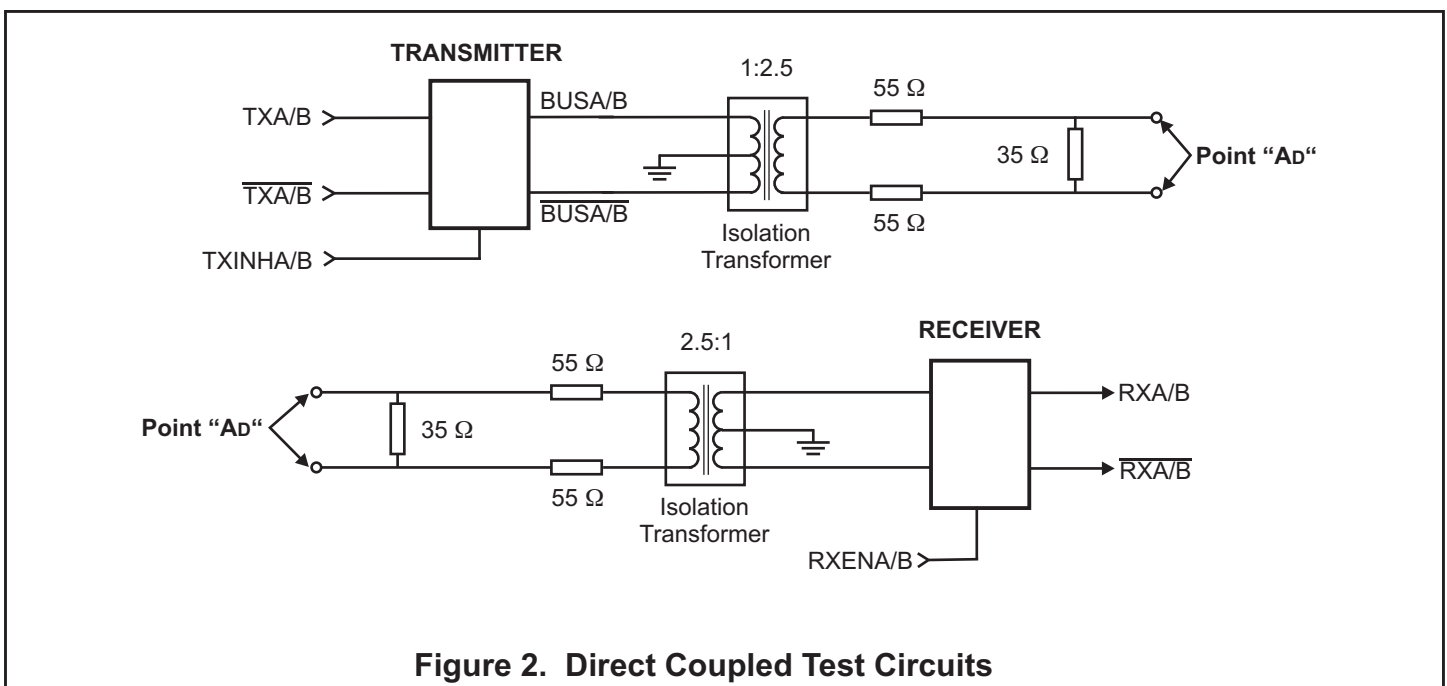

Figure 2. Direct Coupled Test Circuits

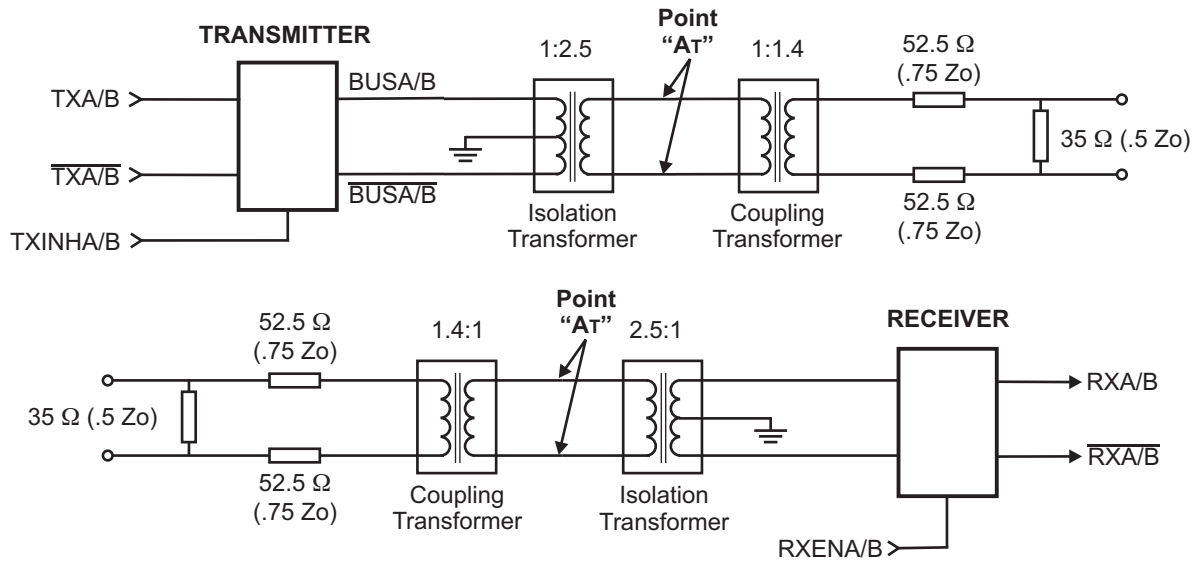

Figure 3. Transformer Coupled Test Circuits

**HEAT SINK - ESOIC & CHIP-SCALE PACKAGE APPLICATIONS NOTE**

The HI-1579PSI/T/M and HI-1581PSI/T/M use a 20-pin thermally enhanced SOIC package. The HI-1579PCI/T/M and HI-1581PCI/T/M use a plastic chip-scale package (QFN). These packages include a metal heat sink located on the bottom surface of the device. This heat sink should be soldered down to the printed circuit board for optimum thermal dissipation. The heat sink is electrically isolated and may be soldered to any convenient power or ground plane.

Holt Applications Note AN-500 provides circuit design notes regarding the use of Holt's family of MIL-STD-1553 transceivers. Layout considerations, as well as recommended interface and protection components are included.

**THERMAL CHARACTERISTICS**

PART NUMBER	PACKAGE STYLE	CONDITION	θ <sub>JA</sub>	JUNCTION TEMPERATURE		
				T <sub>A</sub> =25°C	T <sub>A</sub> =85°C	T <sub>A</sub> =125°C
HI-1579PSI / T / M	20-pin Thermally enhanced plastic SOIC (ESOIC)	Heat sink unsoldered	54°C/W	68°C	130°C	170°C
HI-1581PSI / T / M		Heat sink soldered	47°C/W	63°C	124°C	165°C
HI-1579CDI / T / M	20-pin Ceramic side-brazed DIP	Socketed	62°C/W	74°C	136°C	175°C
HI-1581CDI / T / M						
HI-1579PCI / T / M	44-pin Plastic chip-scale package (QFN)	Heat sink unsoldered	49°C/W	65°C	126°C	166°C
HI-1581PCI / T / M						

Data taken at VDD=3.3V, continuous transmission at 1Mbit/s, single transmitter enabled.

**ORDERING INFORMATION**

**HI - 15xx xx x x (Plastic)**

PART NUMBER	LEAD FINISH
Blank	Tin / Lead (Sn / Pb) Solder
F	100% Matte Tin (Pb-free RoHS compliant)

PART NUMBER	TEMPERATURE RANGE	FLOW	BURN IN
I	-40°C TO +85°C	I	No
T	-55°C TO +125°C	T	No
M	-55°C TO +125°C	M	Yes

PART NUMBER	PACKAGE DESCRIPTION
PC	44 PIN PLASTIC CHIP-SCALE PACKAGE QFN (44PCS)
PS	20 PIN PLASTIC ESOIC, Thermally Enhanced Wide SOIC w/Heat Sink (20HWE)

PART NUMBER	RXENA = 0		RXENB = 0	
	RXA	$\overline{RxA}$	RXB	$\overline{RxB}$
1579	0	0	0	0
1581	1	1	1	1

**HI - 15xxCD x (Ceramic)**

PART NUMBER	TEMPERATURE RANGE	FLOW	BURN IN	LEAD FINISH
I	-40°C TO +85°C	I	No	Gold (Pb-free, RoHS compliant)
T	-55°C TO +125°C	T	No	Gold (Pb-free, RoHS compliant)
M	-55°C TO +125°C	M	Yes	Tin / Lead (Sn / Pb) Solder

PART NUMBER	RXENA = 0		RXENB = 0		PACKAGE DESCRIPTION
	RXA	$\overline{RxA}$	RXB	$\overline{RxB}$	
1579	0	0	0	0	20 PIN CERAMIC SIDE BRAZED DIP (20C)
1581	1	1	1	1	20 PIN CERAMIC SIDE BRAZED DIP (20C)

**RECOMMENDED TRANSFORMERS**

The HI-1579 and HI-1581 transceivers have been characterized for compliance with the electrical requirements of MIL-STD-1553 when used with the following

transformers. Holt recommends the Premier Magnetics parts as offering the best combination of electrical performance, low cost and small footprint.

MANUFACTURER	PART NUMBER	APPLICATION	TURNS RATIO(S)	DIMENSIONS
Premier Magnetics	PM-DB2725EX	Isolation	Dual tapped 1:1.79, 1:2.5	.500 x .500 x .375 inches
Technotrol	TL1553-45	Isolation	Dual tapped 1:1.79, 1:2.5	.630 x .630 x .155 inches
Premier Magnetics	PM-DB2702	Stub coupling	1:1.4	.625 x .500 x .250 inches
Technotrol	TQ-1553-2	Stub coupling	1:1.4	.625 x .625 x .250 inches

## REVISION HISTORY

Document	Rev.	Date	Description of Change
DS1579	F	07/24/09	Correct typographical errors in package dimensions. Clarified available temperature ranges.
	G	10/5/09	Clarified status of RXA/B and $\overline{RXA/B}$ pins in bus idle state when RXENA or RXENB are high (logic "1"). Clarified nomenclature of chip-scale package as QFN. Added 'M' flow option for QFN package ('PCM' package option). Updated datasheet to include HI-1581 variant.
	H	01/26/10	Corrected dynamic current and power dissipation values.
	I	02/01/10	Revised Thermal Characteristic table to correspond to correct dynamic currents and power dissipation values.

**20-PIN PLASTIC SMALL OUTLINE (ESOC) - WB**  
(Wide Body, Thermally Enhanced)

*inches (millimeters)*  
Package Type: 20HWE

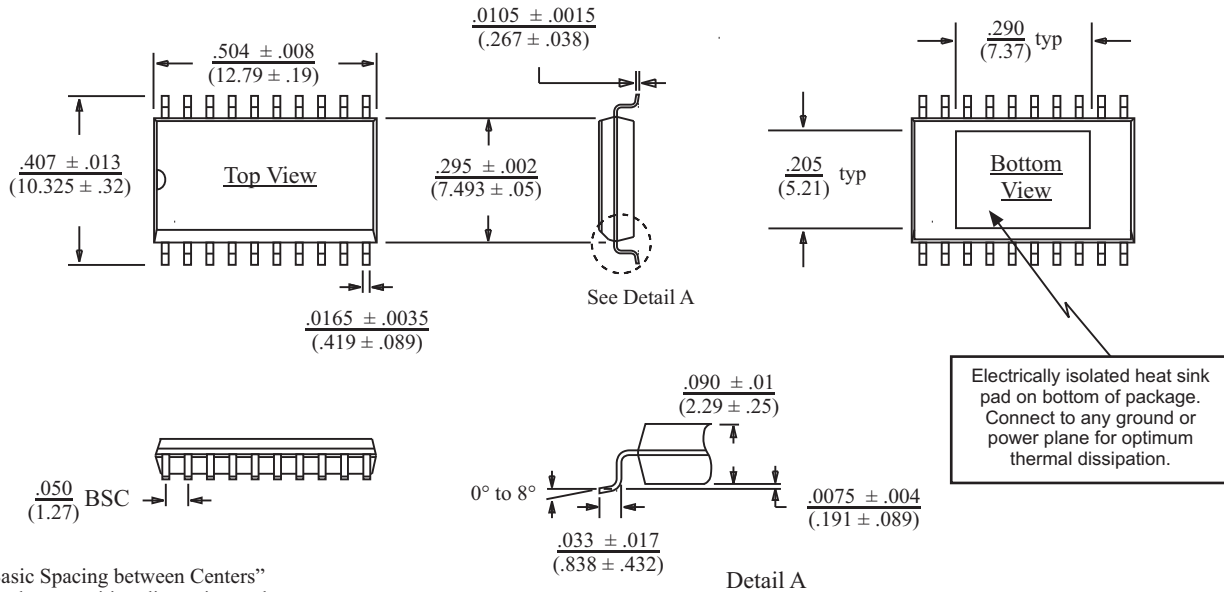

BSC = "Basic Spacing between Centers" is theoretical true position dimension and has no tolerance. (JEDEC Standard 95)

**20-PIN CERAMIC SIDE-BRAZED DIP**

*inches (millimeters)*  
Package Type: 20C

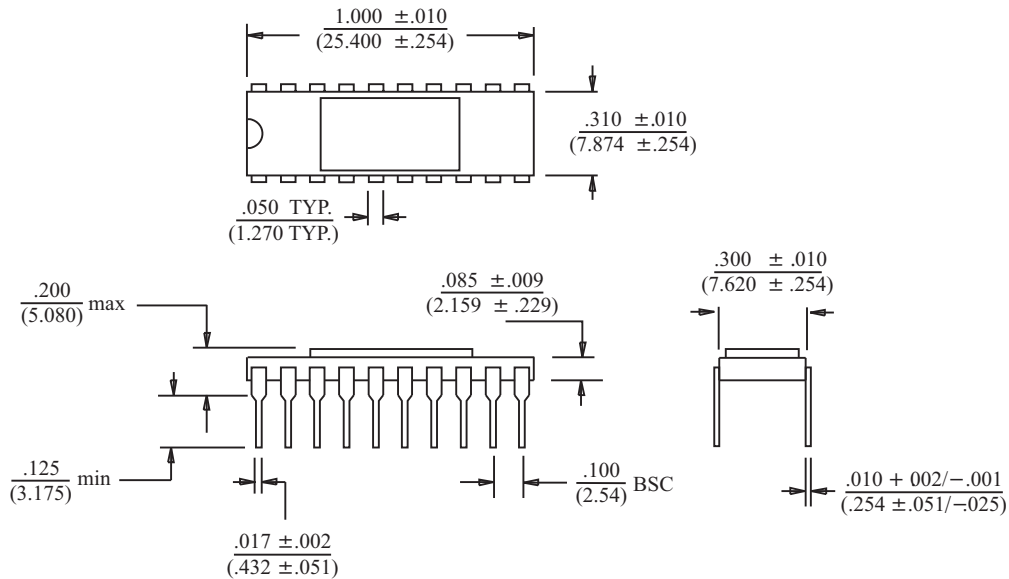

BSC = "Basic Spacing between Centers" is theoretical true position dimension and has no tolerance. (JEDEC Standard 95)

**44-PIN PLASTIC CHIP-SCALE PACKAGE (QFN)**

*inches (millimeters)*

Package Type: 44PCS

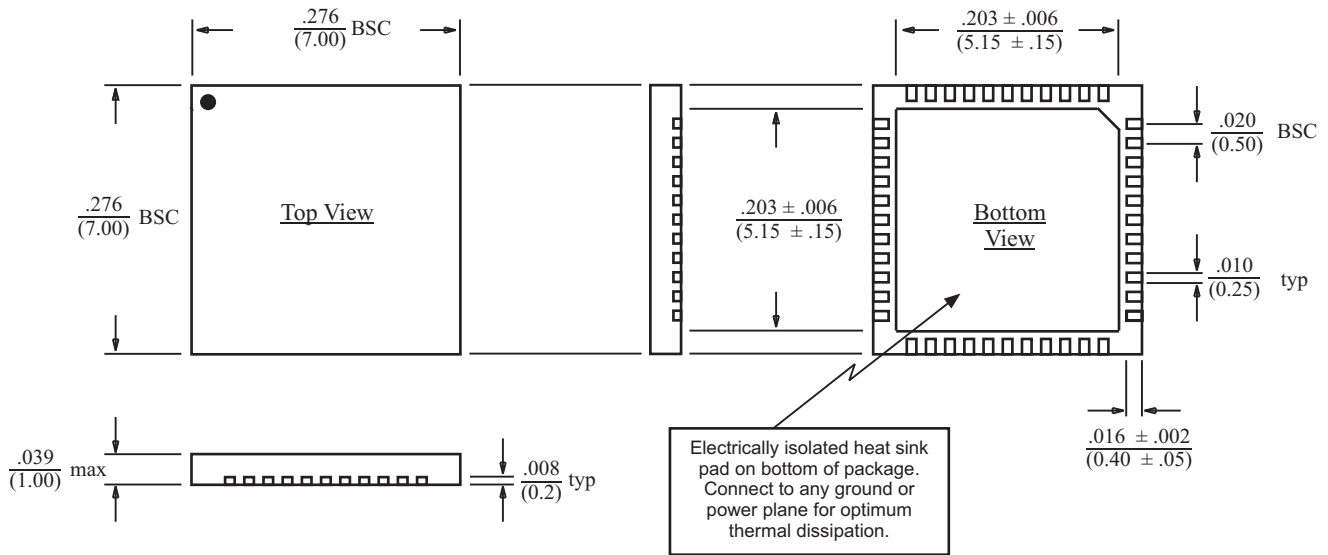

BSC = "Basic Spacing between Centers"  
is theoretical true position dimension and  
has no tolerance. (JEDEC Standard 95)